

CITLF1S

Single Stage Cryogenic SiGe Low Noise Amplifier

KEY FEATURES

- ❖ Ideal for extremely low noise cryogenic applications
- ❖ Powered from a single positive DC supply
- ❖ Female SMA RF connectors
- ❖ 2-pin winchester DC connectors
- ❖ Optional DC bias tees
- ❖ Size 2.2 cm x 1.02 cm x 0.86 cm

PERFORMANCE FEATURES

- ❖ RF Frequency
 - 0.001 to 2.0 GHz
- ❖ Gain
 - < 24 dB
- ❖ Noise Temperature
 - < 7 K
- ❖ Noise Figure
 - < 0.09 dB
- ❖ Optimum DC Power
 - $V_d = 3.0\text{ V}$
 - $I_d = 5.0\text{ mA}$



Description

- The CITLF1S, a single stage SiGe low noise amplifier, is intended for extremely low noise cryogenic applications. The amplifier uses resistive feedback to achieve good input match (S11) and high gain stability. The amplifier is optimum for the frequency range of 0.001 GHz to 2.0 GHz.
- It is powered from a single positive DC power supply which is optimum at 3.0 V.
- The amplifier is 22.2 mm x 10.16 mm x 8.59 mm excluding connectors. Input and output female SMA connectors.

Electrical Specifications @ 12 K

Description	Typical	Minimum	Maximum
RF Frequency	2 GHz	0.001 GHz	3 GHz
Gain	20 dB	16 dB	24 dB
Noise Temperature	< 7 K	4 K	8 K
IRL (-20log S₁₁)	< -15 dB	-15 dB	-20 dB
ORL (-20log S₂₂)	< -10 dB		
DC Voltage	3.0 V		
DC Current	5.0 mA		

Typical Test Results – Optimum DC Bias @ 12 K

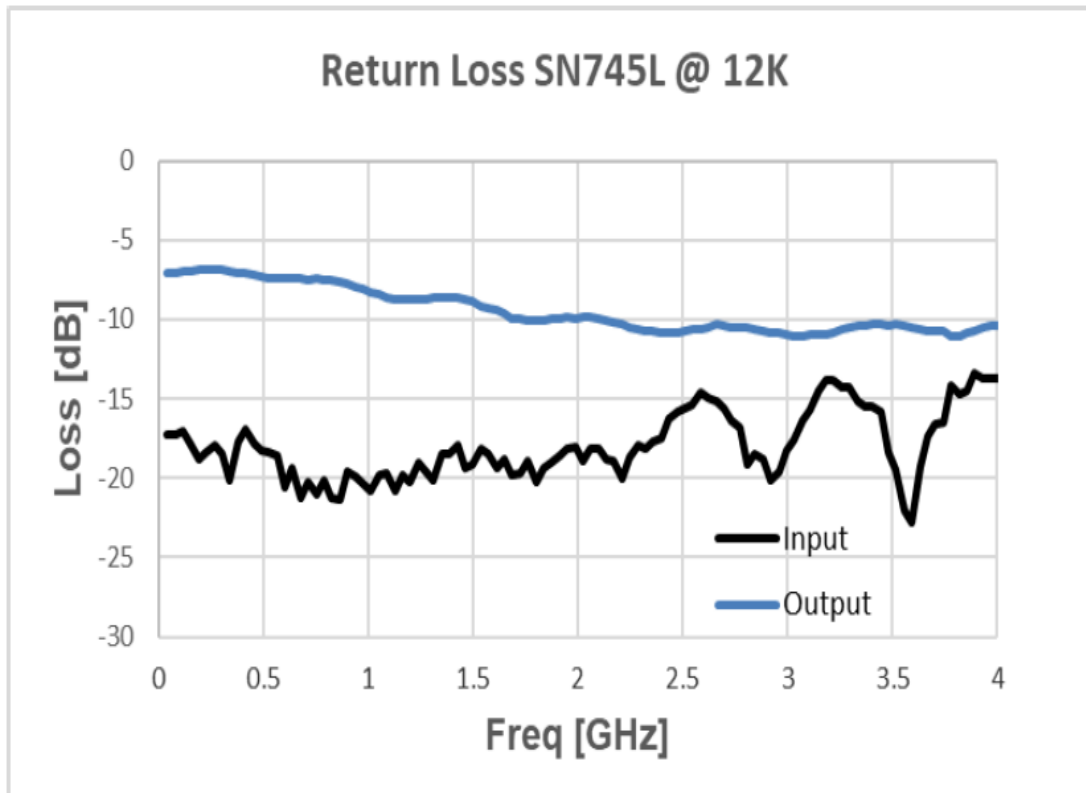
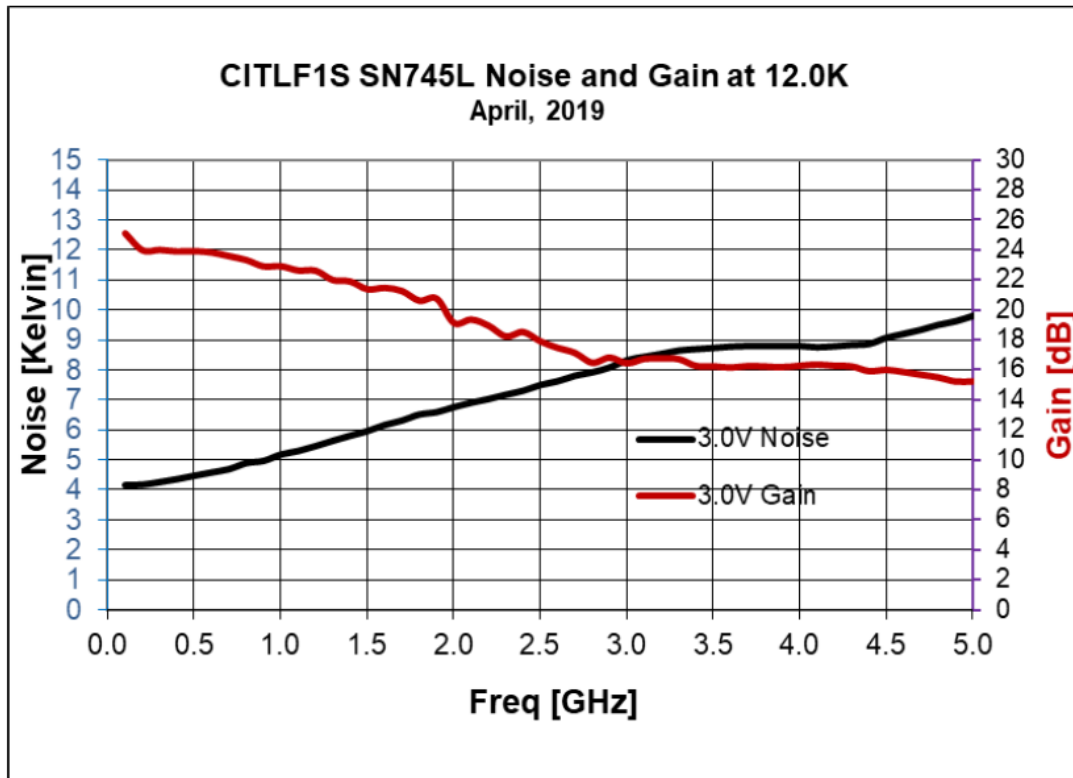

Typical Test Results – 1 dB-Compression Point

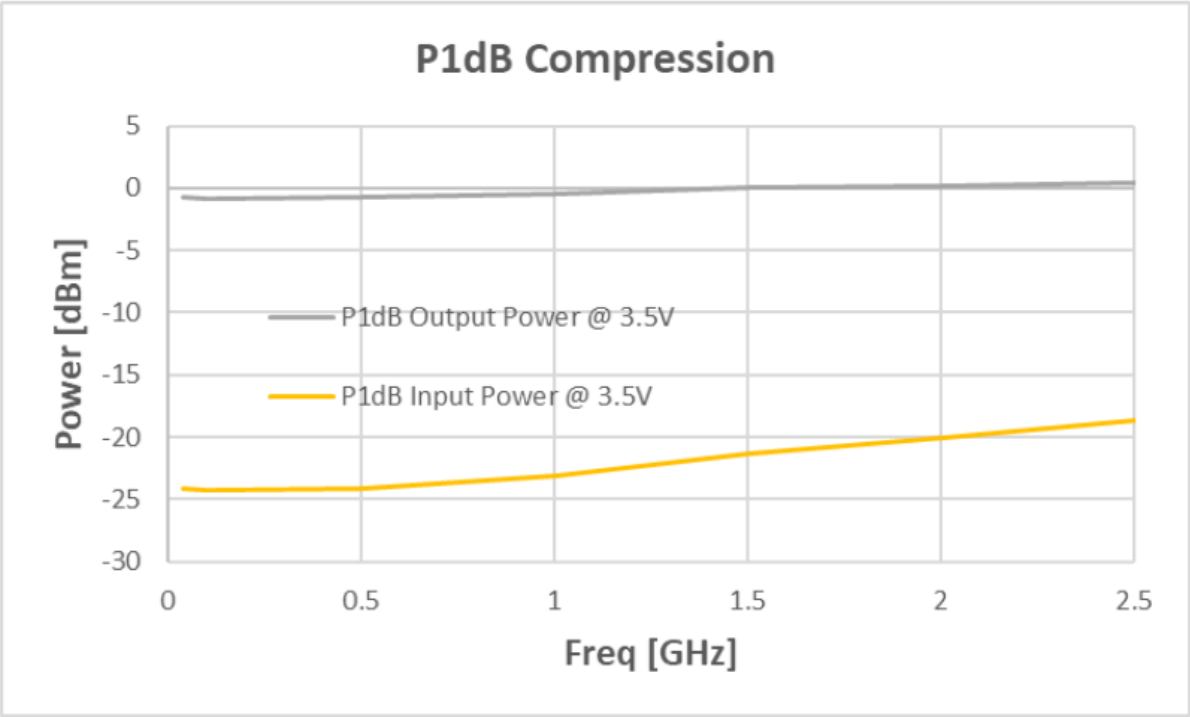

CAD Housing Drawing

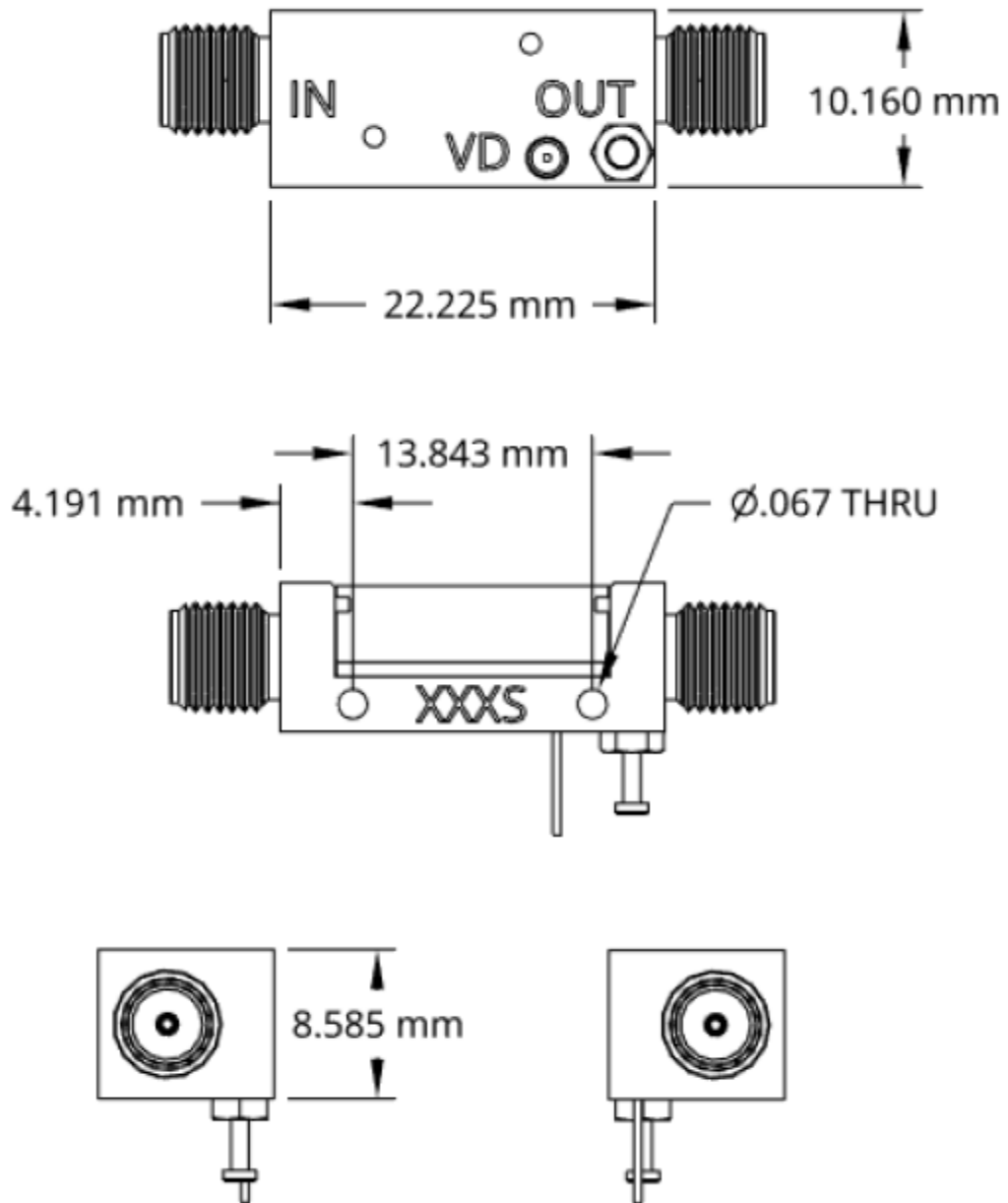

*Dimensions are in mm

Product Care and Maintenance

- Use care to not bend (and break) the DC bias pin when tightening the output SMA connector.
- The amplifier should not be connected to the power supply when connecting the input connector.
- Set the power of Port 1 in your VNA to be less than -45 dB when testing the amplifier. Otherwise, the amplifier may saturate and the data obtained will be incorrect.
- Do not attempt to open the amplifier.
- Electrostatic discharge can damage the amplifier.

Contact Information

Sales & Quotes

Name Denise Smith
Email Address Denise@CosmicMicroTech.com
Phone Number +1 (424) 456-7722
Address 15703 Condon Avenue, Unit C4, Lawndale, CA 90260, USA

Technical Questions

Name Stephen Smith
Email Address Steve@CosmicMicroTech.com
Phone Number +1 (424) 456-7744
Address 15703 Condon Avenue, Unit C4, Lawndale, CA 90260, USA