



NEW! Miniaturized NEW! Multi-Channel

CITCRYO4-12B

Cryogenic HEMT Low Noise Amplifier

KEY FEATURES

- Frequency Range 4–12 GHz
- Very low noise, Minimum 2.5K, Maximum 6K.
- Input/Output return loss is <-10 dB.
- Can operate as low as 10mW with reduced gain.

PERFORMANCE FEATURES

- RF frequency
 - 4 to 12 GHz
- Gain
 - 35 dB \pm 2 dB
- Average noise temperature
 - < 3.5 Kelvin
- Average noise figure
 - 0.05 dB

APPLICATIONS

- ✓ Radio astronomy arrays
- ✓ Satellite and Space Communication
- ✓ Research & development

Description

The CITCRYO4-12B is a cryogenic, low noise amplifier suitable for Radio Astronomy and Quantum applications. The amplifier covers the band from 4 to 12 GHz and is useable to 14 GHz. The amplifier has a typical noise temperature of 3.5 K with a gain of 35 dB. The standard configuration comes with SMA female connectors. The amplifier is also available in our NEW miniature “Drop-In” version which is 10 mm x 10 mm. CMT has also introduced a dual amplifier configuration, and a chassis that incorporated shielded SMA connectors for *ALL* DC connections, amplifier supply and input DC Bias tees.

DC CONNECTIONS FOR HIGH NOISE ENVIRONMENTS

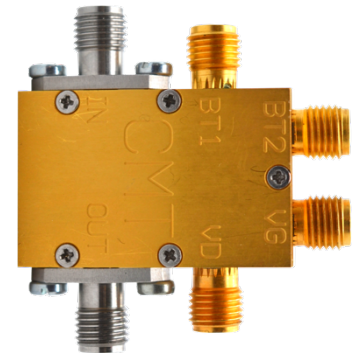

New shielded SMA connectors

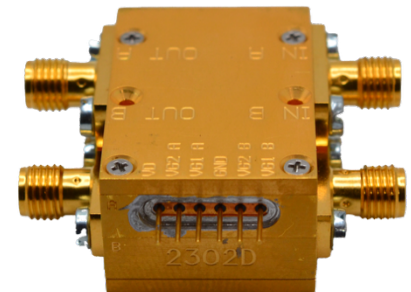

New Multi-Channel

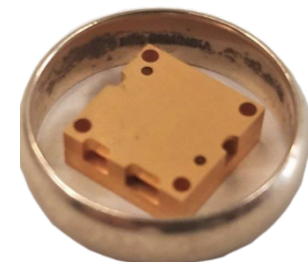

New Reduced Size

Electrical Specifications @ 12 K

Description	Typical	Minimum	Maximum
RF Frequency	2.5–15 GHz	4 GHz	12 GHz
Gain	35 dB	35 dB ± 2 dB	
Noise Temperature	3.5K	2.5K	6K
IRL (-20log S ₁₁)	-15 dB	< -10 dB	
ORL (-20log S ₂₂)	-15 dB	< -10 dB	
Drain Voltage	1.2 V	0.6 V	1.5 V

Electrical Specifications @ 300 K

Description	Typical	Minimum	Maximum
RF Frequency	2.5–14 GHz	4 GHz	12 GHz
Gain	35 dB	35 dB ± 2 dB	
Noise Temperature	50 K	33K	56K
IRL (-20log S ₁₁)	-15 dB	< -10 dB	
ORL (-20log S ₂₂)	-15 dB	< -10 dB	
DC Voltage	1.8 V	1.0 V	2.0 V

Typical Test Results – Optimum DC Bias @ 12 K

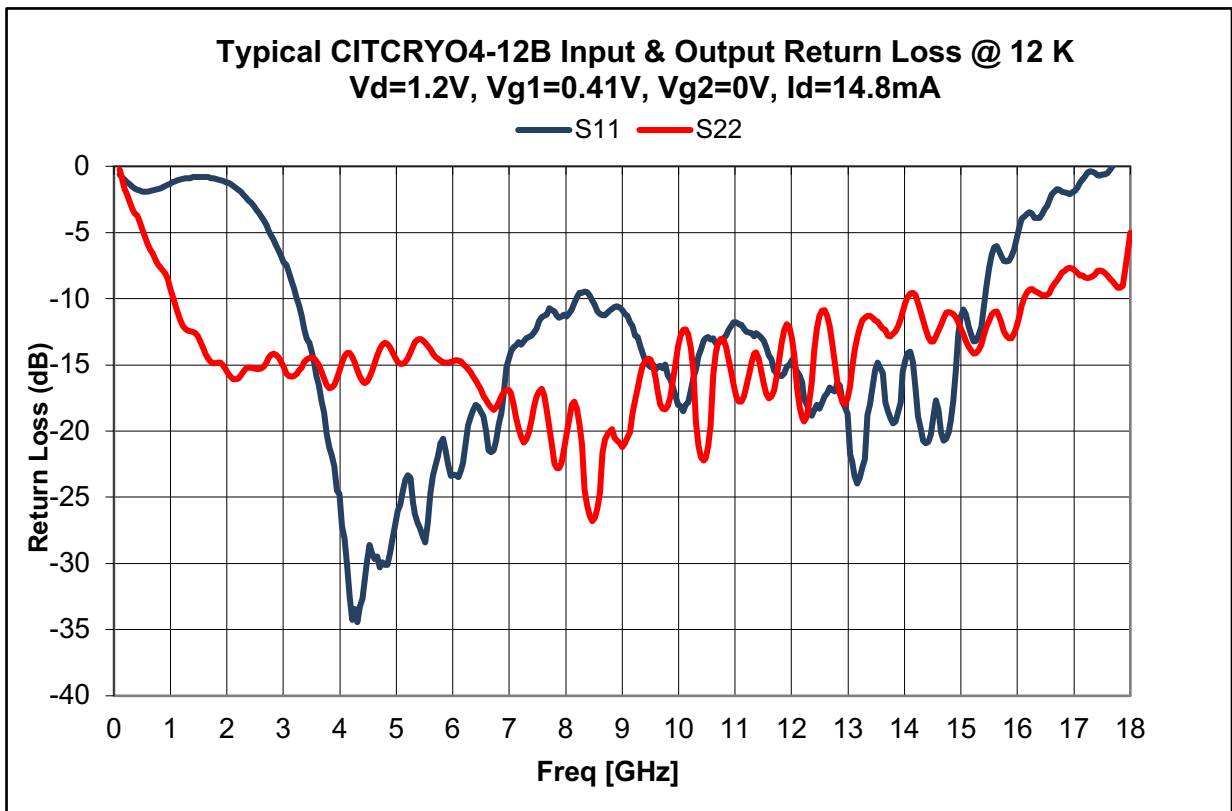
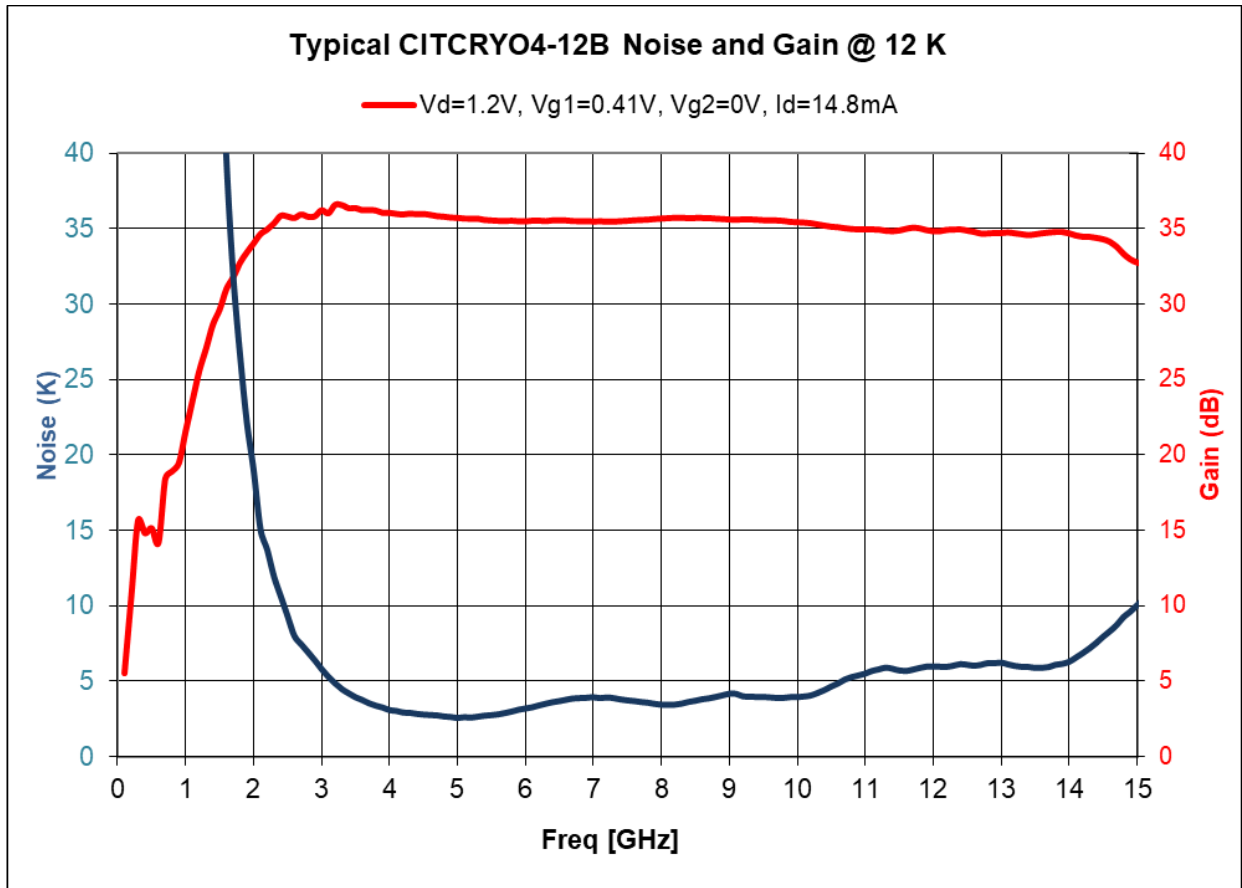

Typical Test Results – DC Bias Sweep @ 12 K

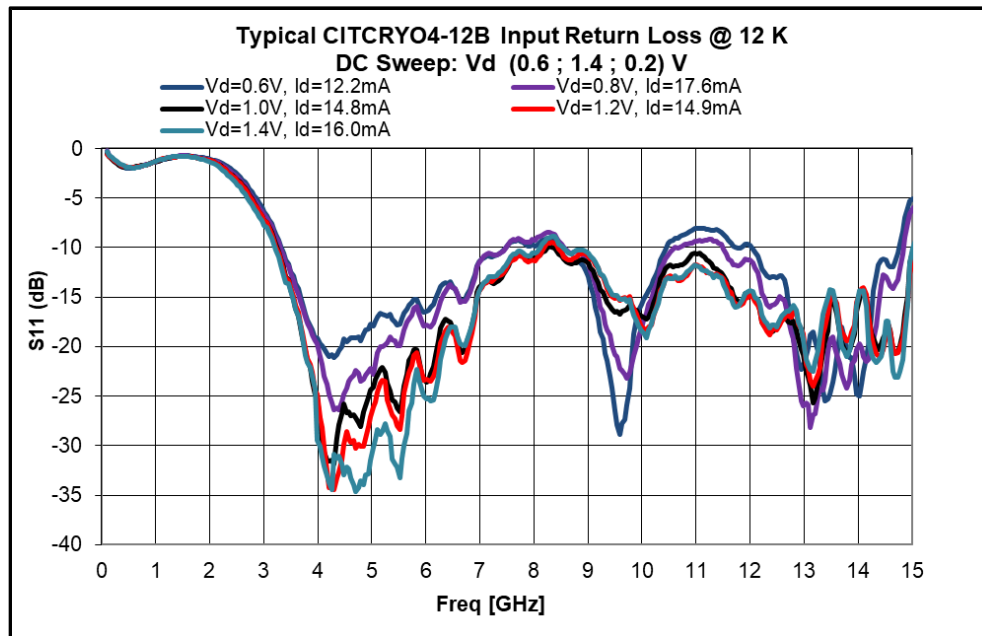
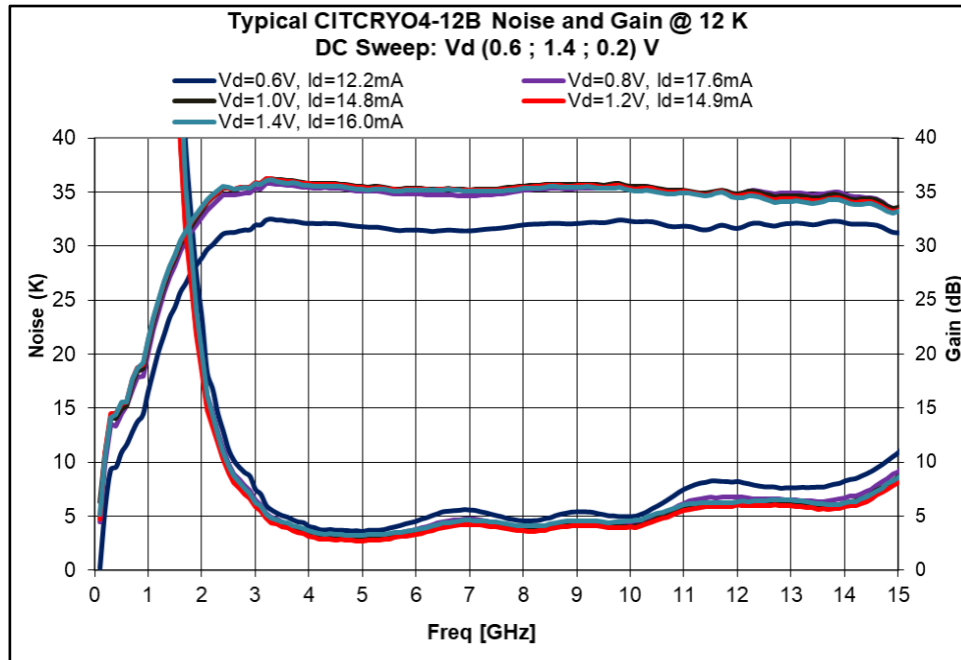

Vd (V)	Vg1 (V)	Vg2 (V)	Id (mA)
0.6	0.37	0.47	12.2
0.8	0.45	0.54	17.6
1.0	0.51	0.23	14.8
1.2	0.41	0.00	14.9
1.4	0.54	-0.14	16.0

Typical Test Results – Gain Compression, P1dB

$V_d=1.2V$, $T_c=12K$

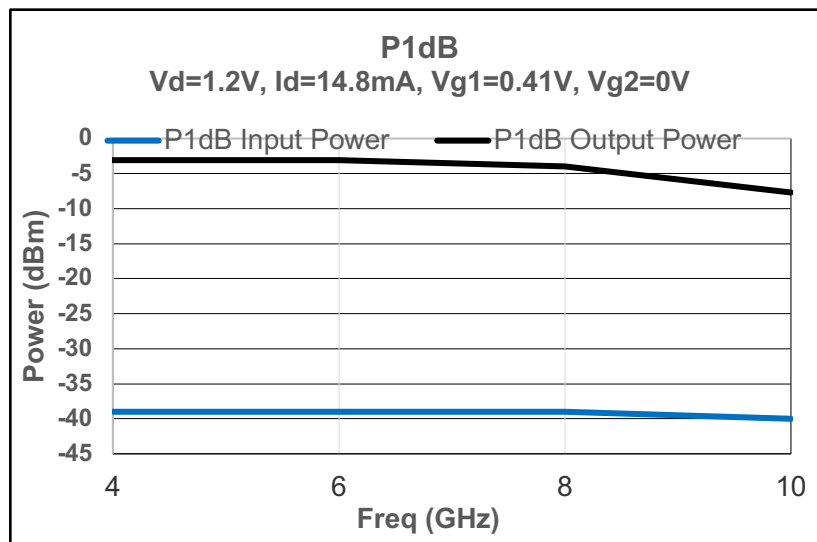
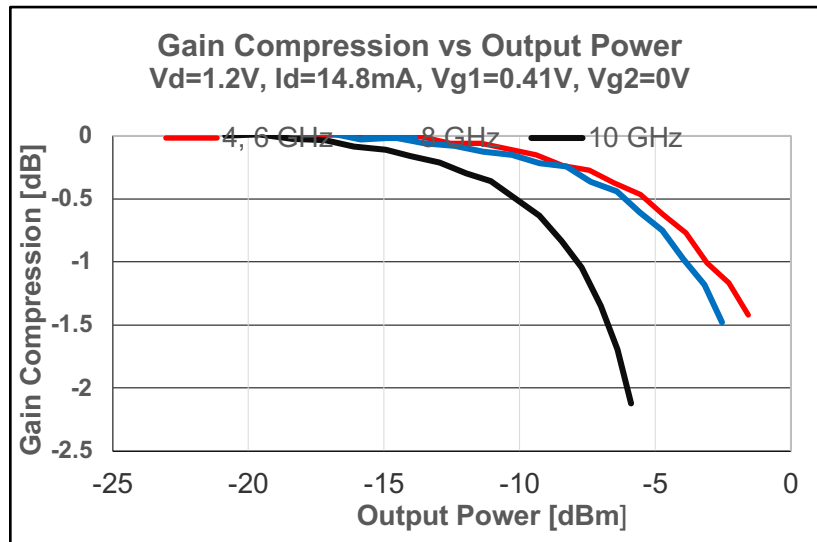
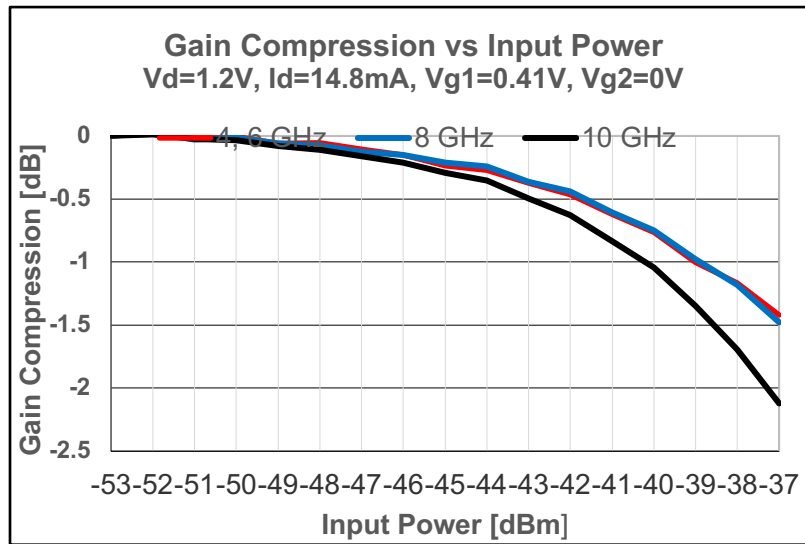

Typical Test Results – Gain Compression, P1dB

$V_d=0.5V$, $T_c=12K$

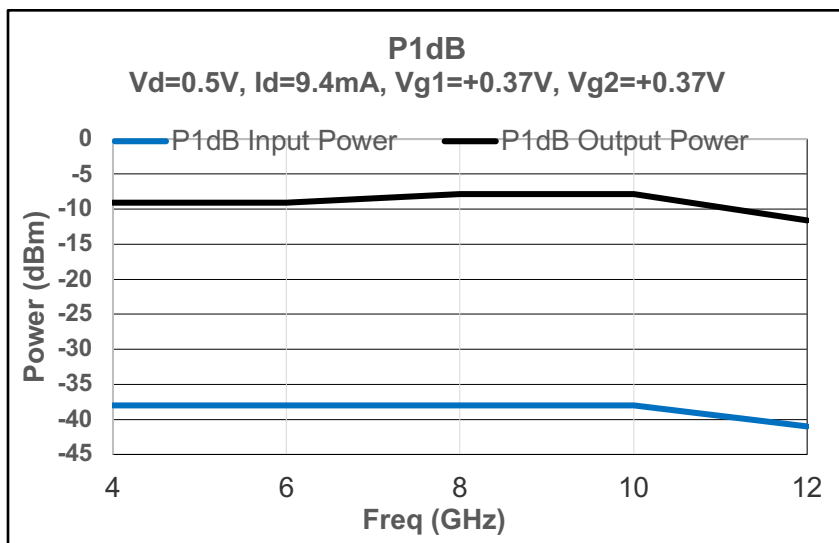
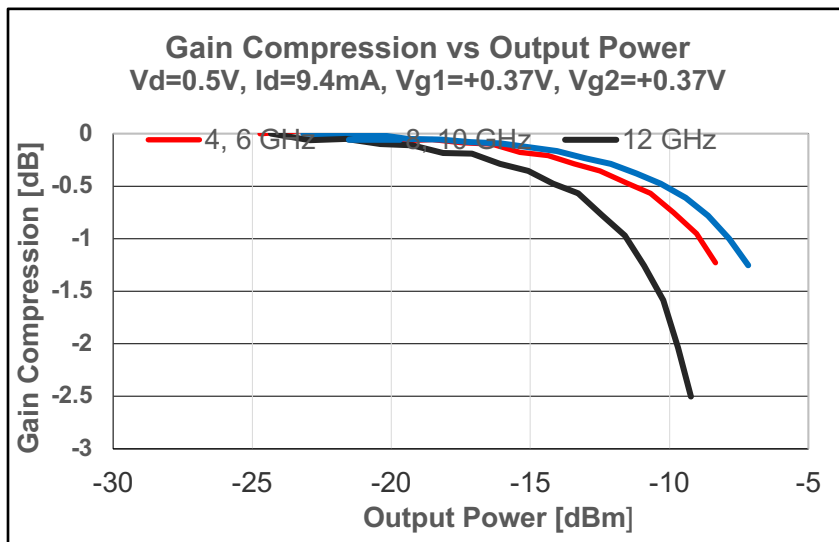
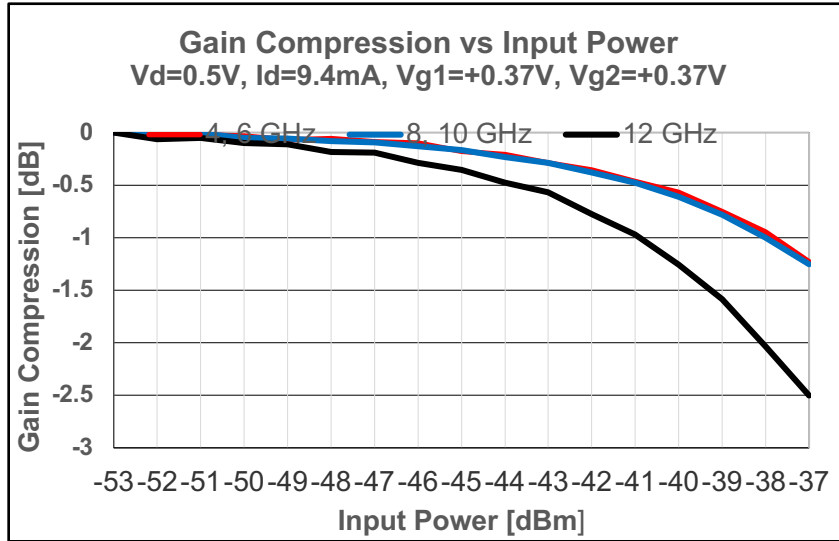

Typical Test Results – Optimum DC Bias @ 300 K

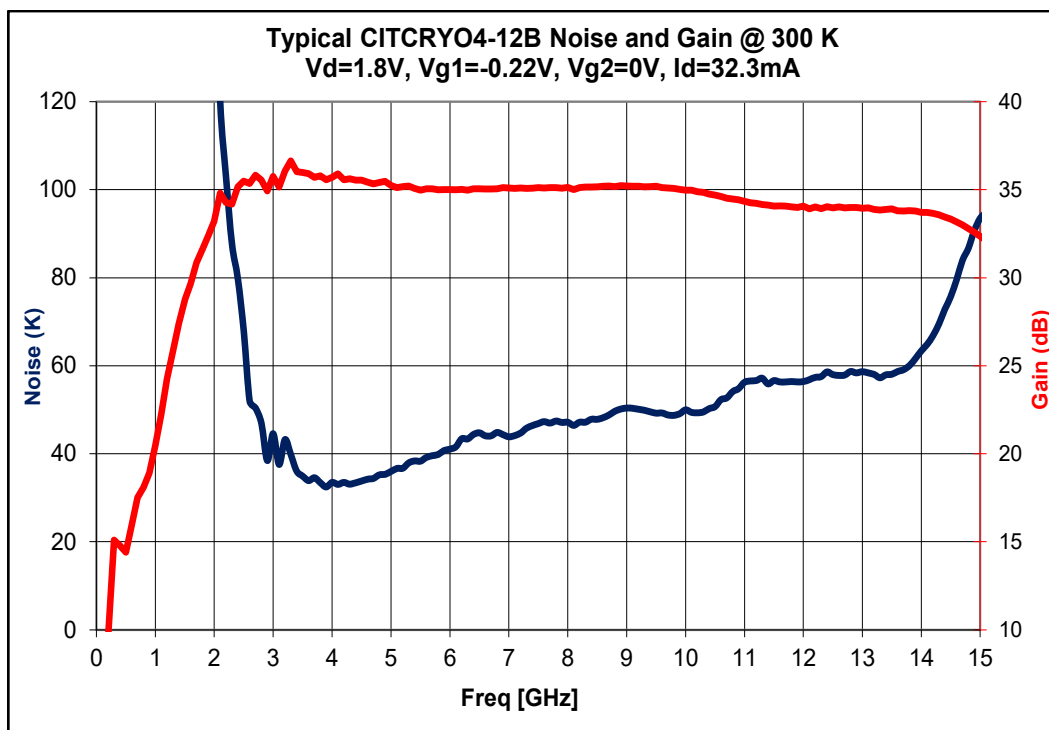

CAD Housing Drawing

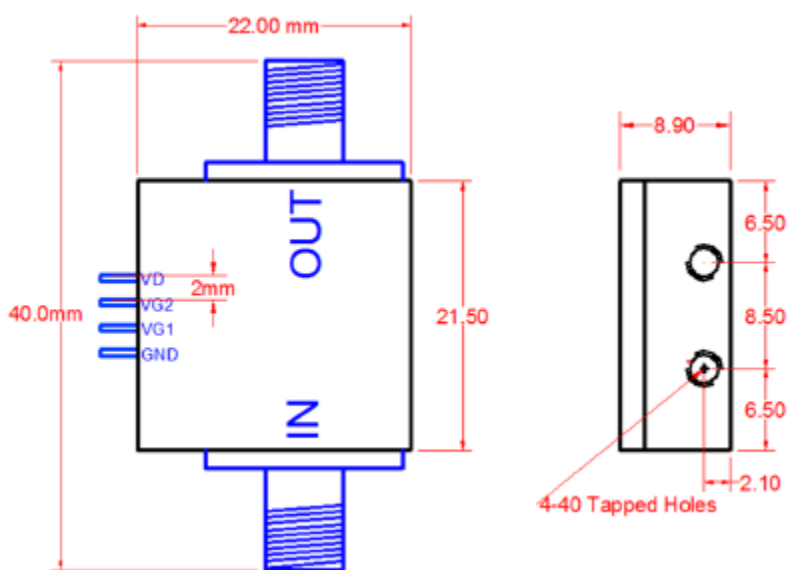

*Dimensions are in mm

CAD Housing Drawing – Miniature

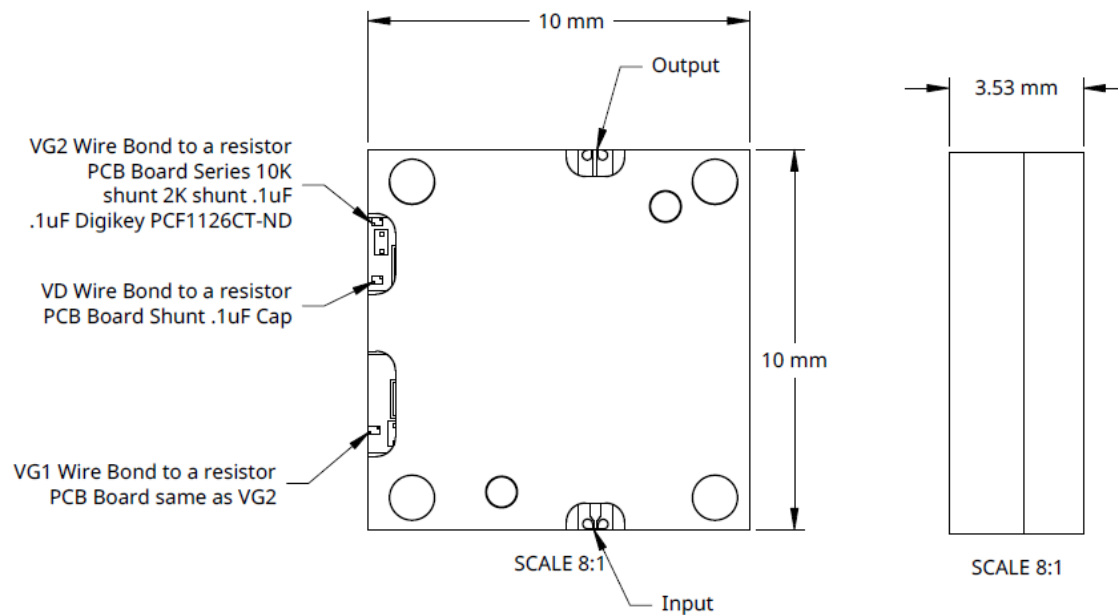

*Dimensions are in mm

CAD Housing Drawing – Multi-Channel

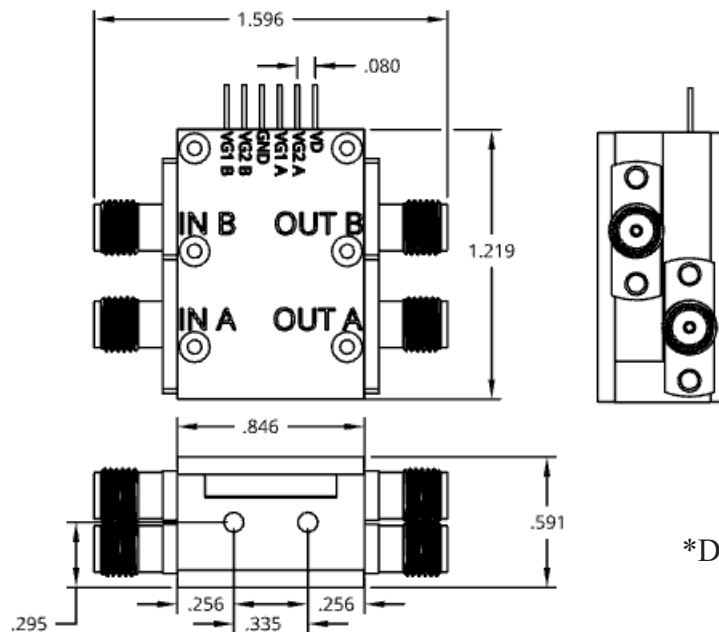

*Dimensions are in mm

CAD Housing Drawing – Shielded SMA Connectors

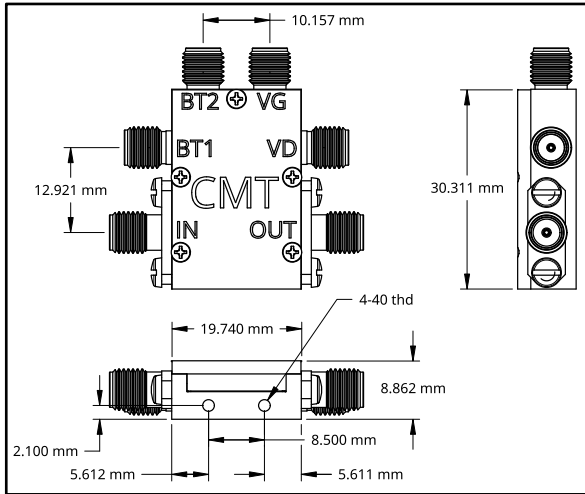

Optional Input Bias Tee

As an option, the amplifier can be supplied with a DC bias tee for an external device connected to the amplifier input. The bias tee is formed by two (2) resistors connected to the input; as shown in Figure 1. One (1) resistor can be used as a source of current and the other senses the voltage across the external device. Voltages applied to the bias tee have a small effect on amplifier operation. At 12 K, 20 KΩ resistors increase noise by 0.5 K.

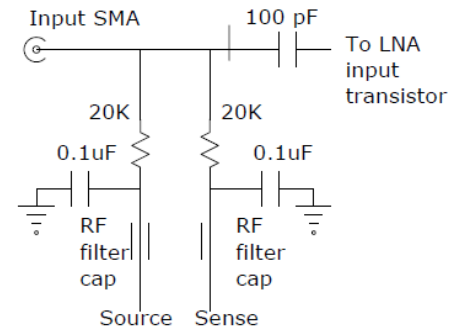
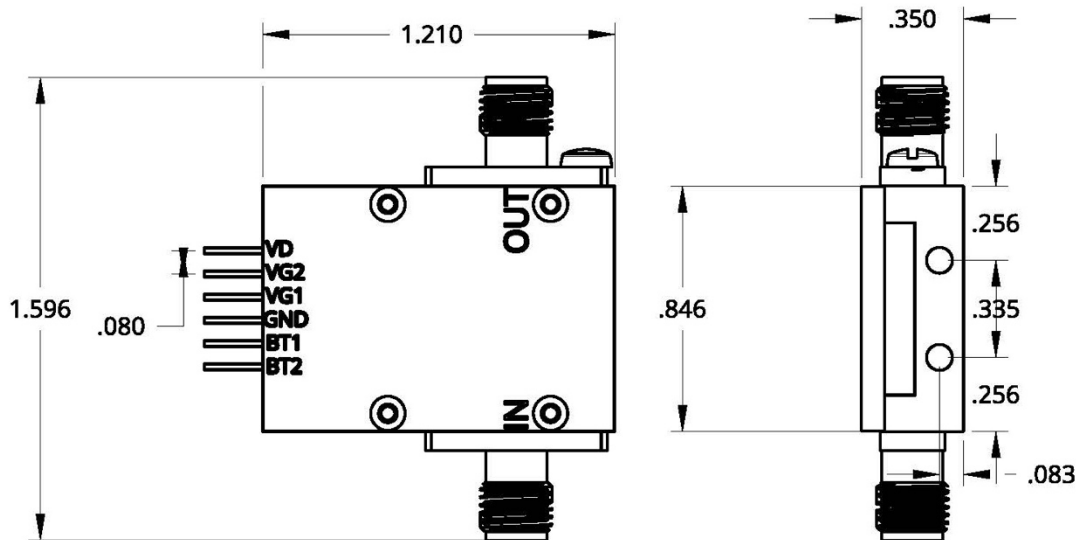

Figure 1. Bias Tee Schematic



Optional Input Protection Diodes

As an option, the amplifier can be supplied with ESD protection & voltage spike protection at the RF input to the amplifier. There will be a slight degradation of the amplifier performance. Please note that the optional input protection diodes cannot be used if DC voltages are applied to the RF line using input bias tees.

To order an amplifier with internal bias resistors, add the resistance to the part #. For instance, CITCRYO4-12B-PD.

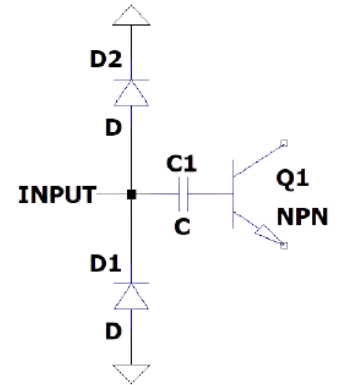

D1 & D2 = Input Protection Diodes

Figure 2. Protection Diodes Schematic

Product Care and Maintenance

- Use care to not bend (and break) the DC bias pin when tightening the output SMA connector.
- The amplifier should not be connected to the power supply when connecting the input connector.
- Set the power of Port 1 in your VNA to be less than -45 dB when testing the amplifier. Otherwise, the amplifier may saturate, and the data obtained will be incorrect.
- Do not attempt to open the amplifier.
- Electrostatic discharge may damage the amplifier.

Contact Information

Sales & Quotes

Sales@CosmicMicroTech.com

Non-Technical Questions

Name Ms. Denise L. Smith
Email Address Denise@CosmicMicroTech.com
Phone Number +1 (424) 456-7722
Address 15711 Condon Avenue, Unit A3, Lawndale, CA 90260, USA

Technical Questions

Name Mr. Stephen Smith
Email Address Steve@CosmicMicroTech.com
Phone Number +1 (424) 456-7744
Address 15711 Condon Avenue, Unit A3, Lawndale, CA 90260, USA

Specifications are subject to change without notice. Information supplied by CMT is accurate and reliable to the best of our knowledge.