



# NEW! Miniaturized NEW! Multi-Channel

## CITLF2

### Cryogenic SiGe Low Noise Amplifier

#### KEY FEATURES

- Applications include Radio Astronomy and Low Temperature Physics
- Single Supply Operation
- Female SMA Connectors Standard
- SMPM Connectors Available
- Optional input DC Bias Tees
- Standard size 27.1 x 15.9 x 8.7 mm
- Miniature size 21.3 x 10.4 x 8.5 mm
- Quad Amplifier size 25.3 x 32.2 x 8.3 mm

#### PERFORMANCE FEATURES

- RF Frequency
  - 0.01 to 1.5 GHz
- Gain
  - 33 dB ± 3 dB
- Noise Temperature
  - < 3.5 K 10-1500 MHz
- Noise Figure
  - < 0.06 dB
- Optimum DC Power
  - Vd = 2.0 V
  - Id = 11.1 mA

#### APPLICATIONS

- ✓ Radio Astronomy Arrays
- ✓ Superconducting Nano Wire Single Photon Detectors
- ✓ Low Temperature Physics Experiments

## Description

The CITLF2, a SiGe low noise amplifier, is intended for extremely low noise cryogenic applications. The amplifier uses resistive feedback to achieve good input match (S11) and high gain stability. The amplifier is optimum for the frequency range of 0.01 GHz to 1.5 GHz. High gain and low noise is also achieved up to 5 GHz.

It is powered from a single positive DC power supply which is optimum at 2.0 V, but can be reduced to as low as 1.1 V for low power dissipation. Application of up to 5 V will not damage the amplifier. It is recommended that the power supply for the amplifier to be current limited to 100 mA.

The standard chassis is 27.1 X 15.9 X 8.7 mm excluding connectors. The amplifier is also available in our NEW miniature version which is 21.3 X 10.4 X 8.5 mm without bias tees and 23.0 X 13.2 X 8.5 mm with bias tees.

CMT is also producing a Quad amp version which contains four independent amplifiers in a single package with the size of 25.3 x 32.2 x 8.3 mm and a dual amplifier configuration, and a chassis that incorporated shielded SMA connectors for ALL DC connections, amplifier supply and input DC Bias tees.

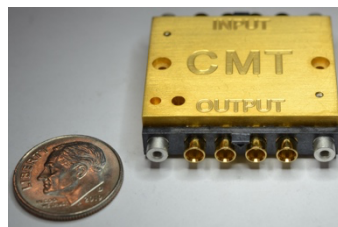

Multichannel Quad Amp

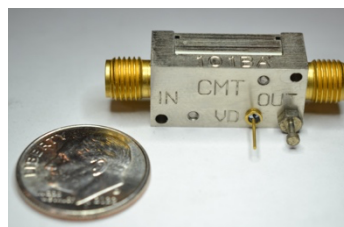

Miniature BA Chassis

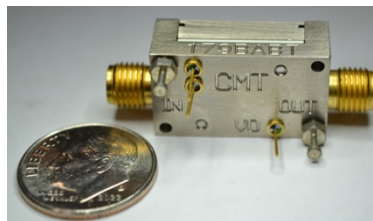

Miniature BAPT with Bias Tees

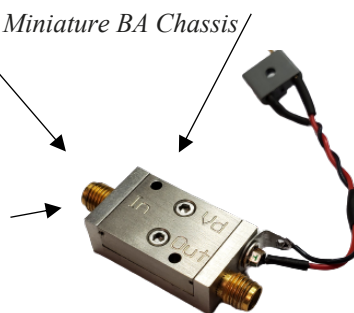

#### DC CONNECTIONS FOR HIGH NOISE ENVIRONMENTS



New shielded SMA connectors

## Electrical Specifications @ 12 K

Description	Typical	Minimum	Maximum
RF Frequency		0.01 GHz	1.5 GHz
Gain		33 dB $\pm$ 3 dB	
Noise Temperature	< 3K		
IRL (-20log S <sub>11</sub>  )		< -10 dB	
ORL (-20log S <sub>22</sub>  )		< -10 dB	
DC Voltage	2.0 V	1.1 V	5 V
DC Current	11.1 mA	1.3 mA	44 mA

## Electrical Specifications @ 300 K

Description	Typical	Minimum	Maximum
RF Frequency		0.01 GHz	1.5 GHz
Gain		25 dB $\pm$ 3 dB	
Noise Temperature	< 70 K		
IRL (-20log S <sub>11</sub>  )		< -10 dB	
ORL (-20log S <sub>22</sub>  )		< -10 dB	
DC Voltage	2.0 V	1.1 V	5 V
DC Current	12.1 mA	3.7 mA	44 mA

# Typical Test Results – Optimum DC Bias @ 12 K

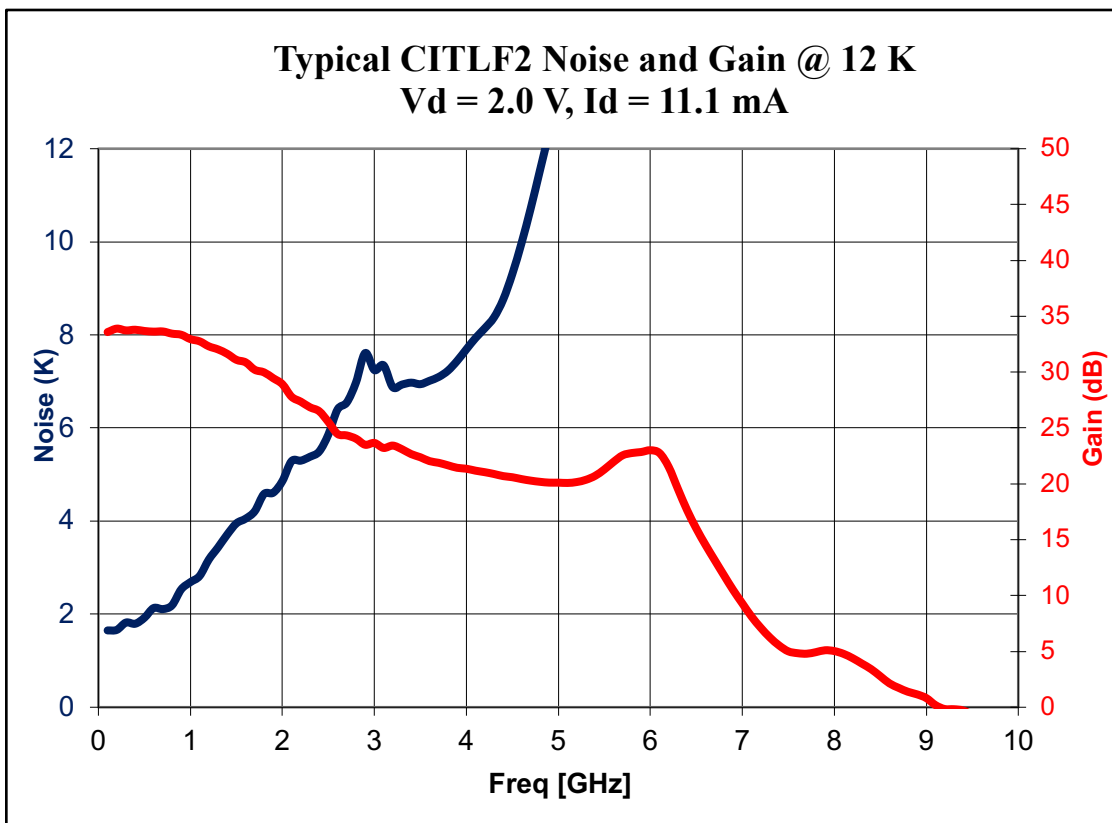
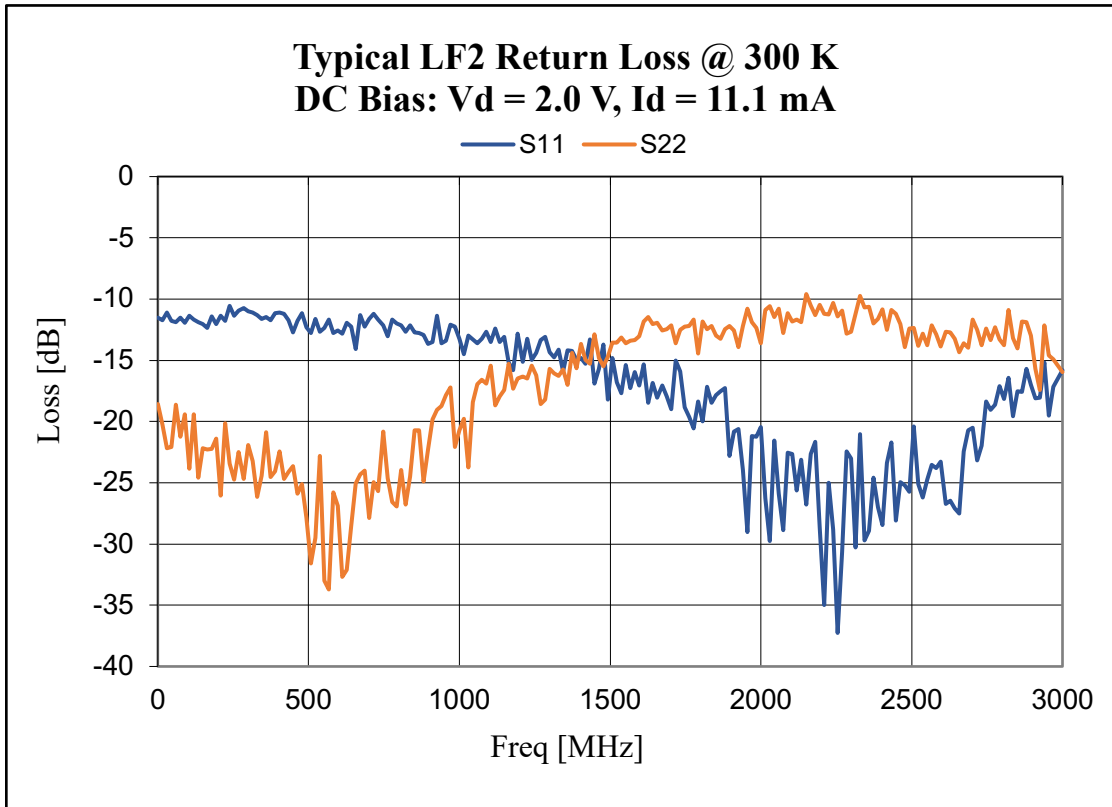

# Typical Test Results – DC Bias Sweep @ 12 K

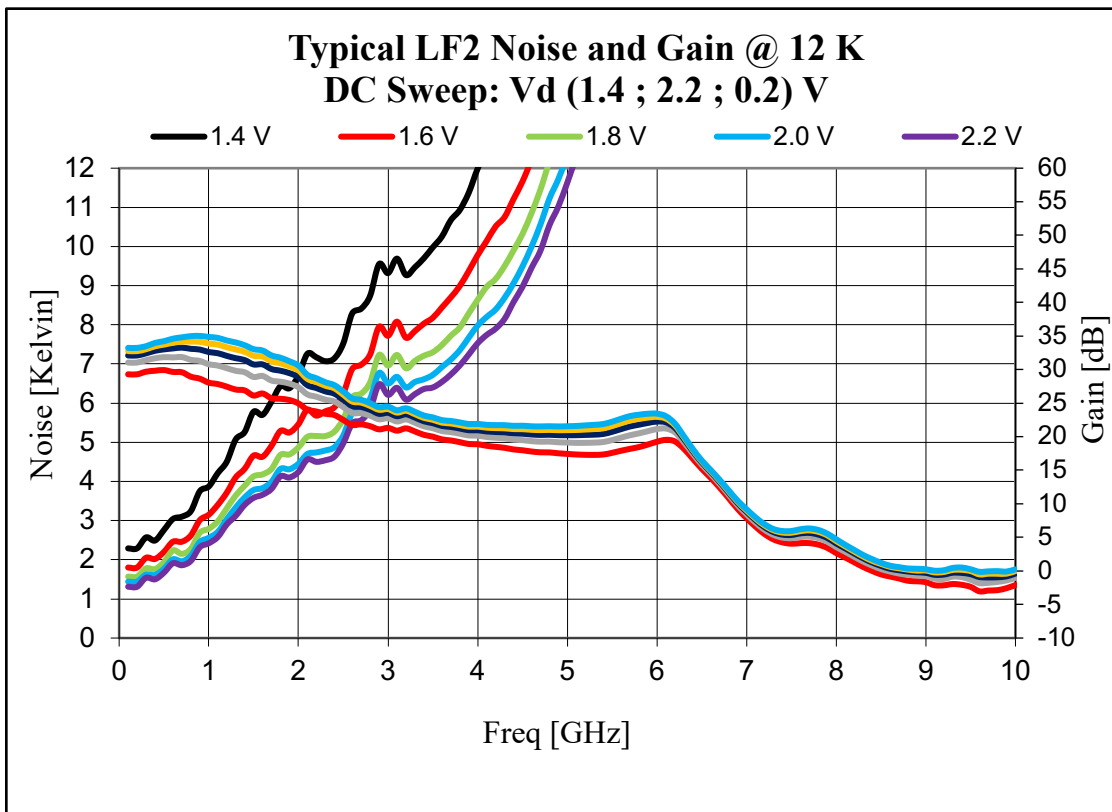
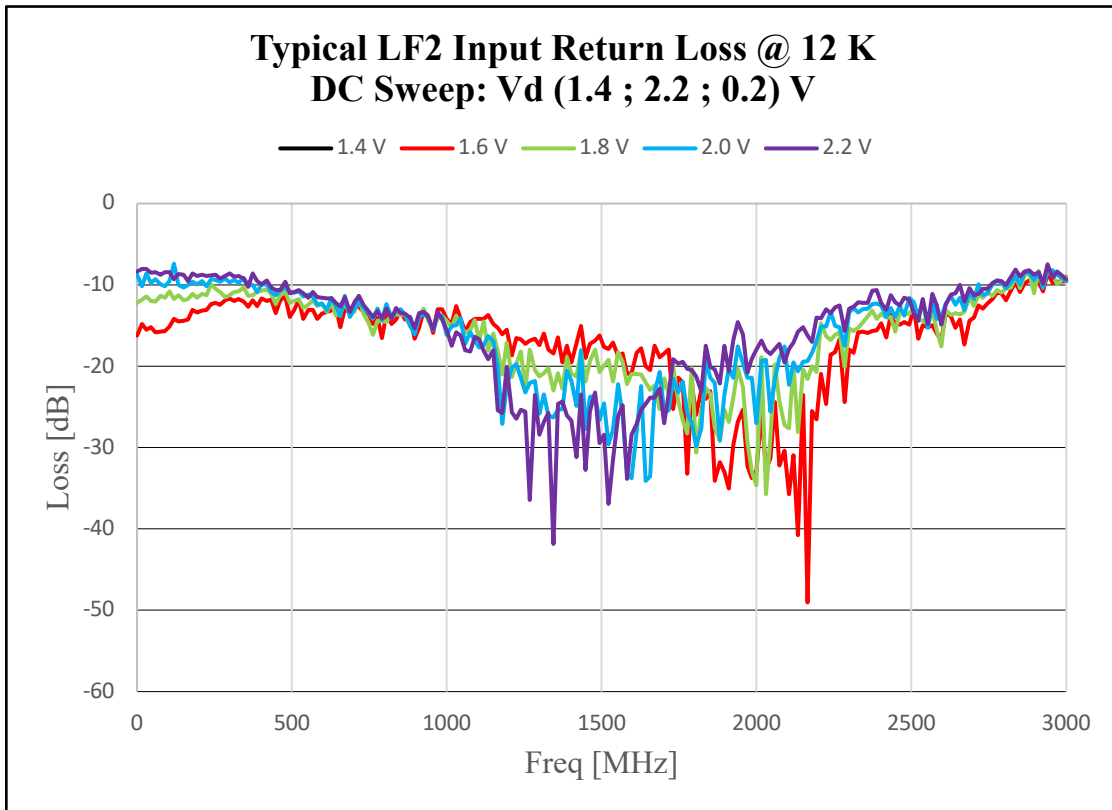

# Typical Test Results – Optimum DC Bias @ 300 K

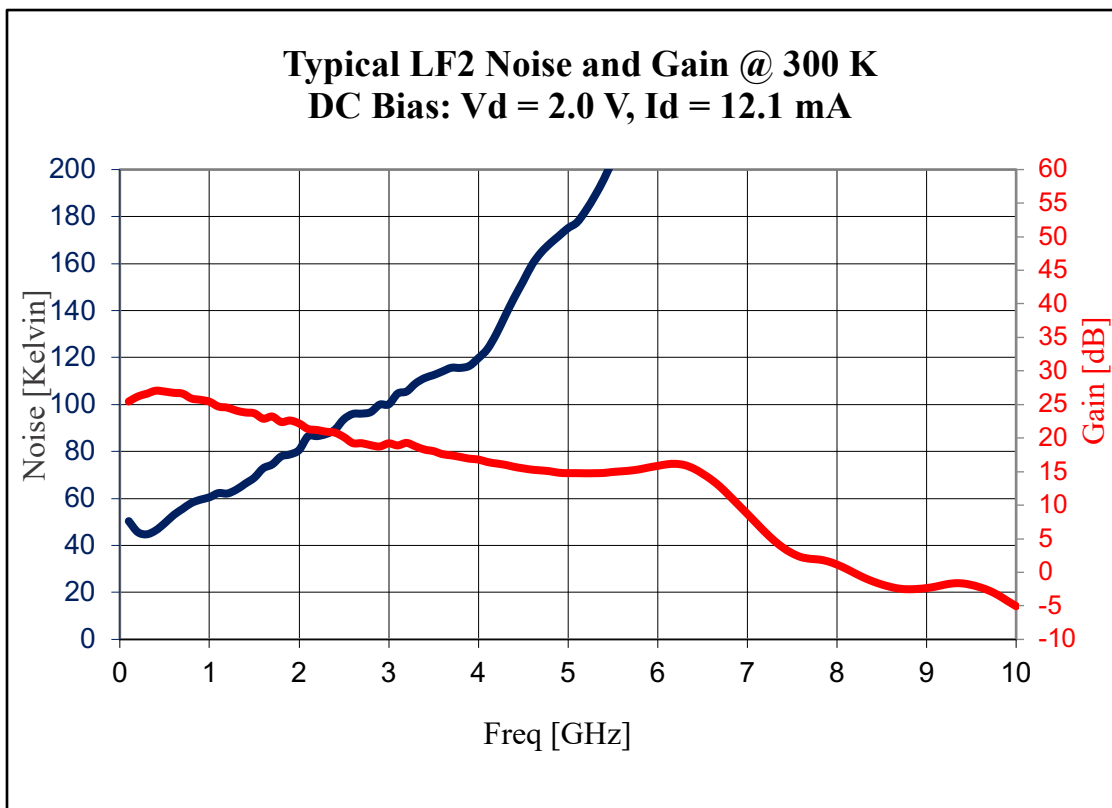
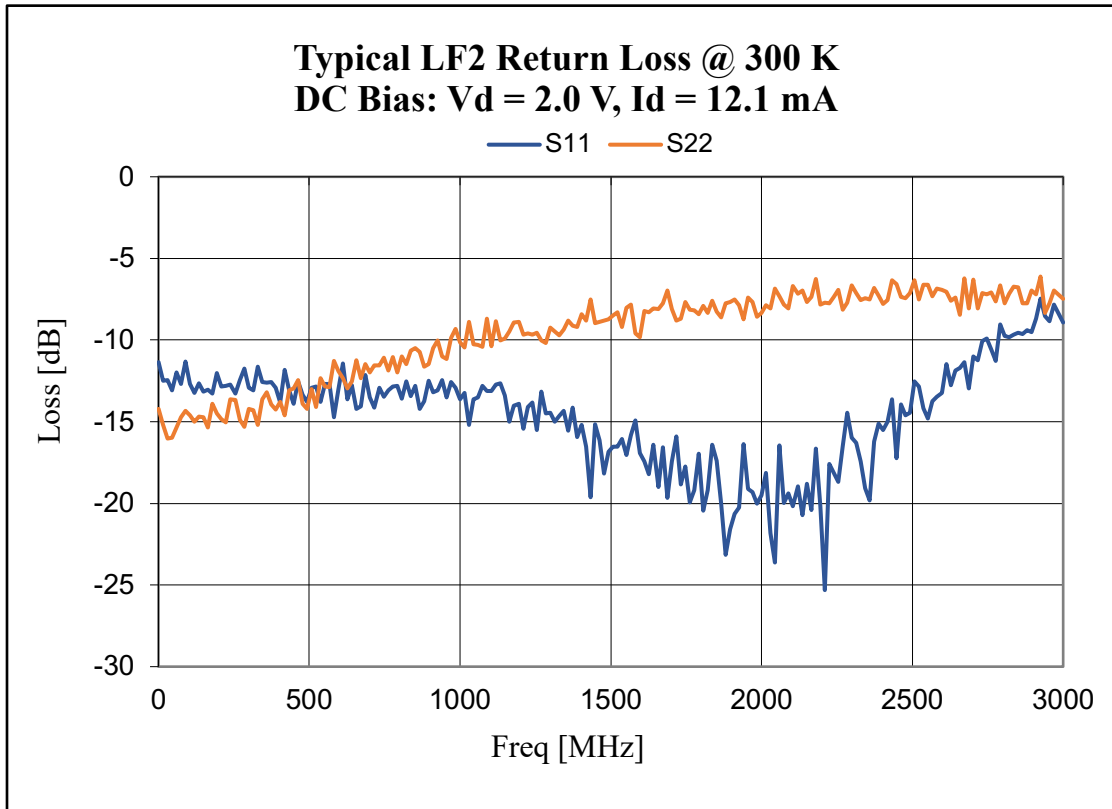

# CAD Housing Drawing

## Regular Chassis

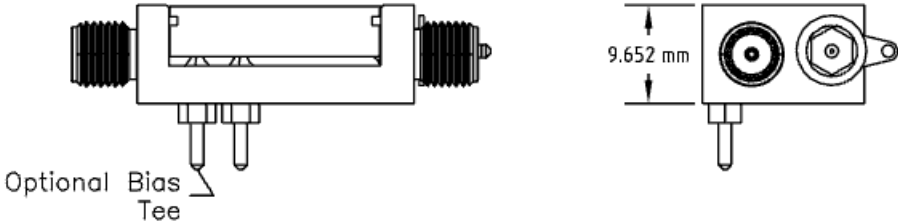
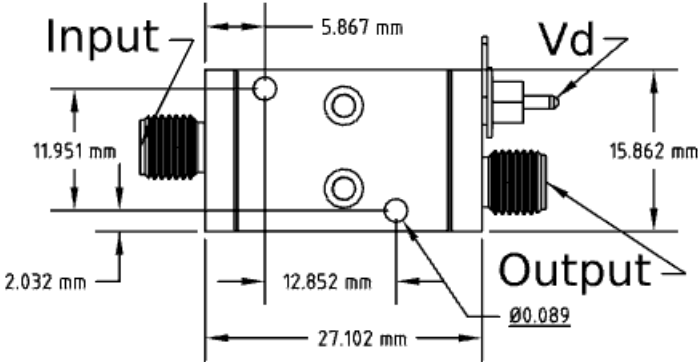

## Miniature Chassis

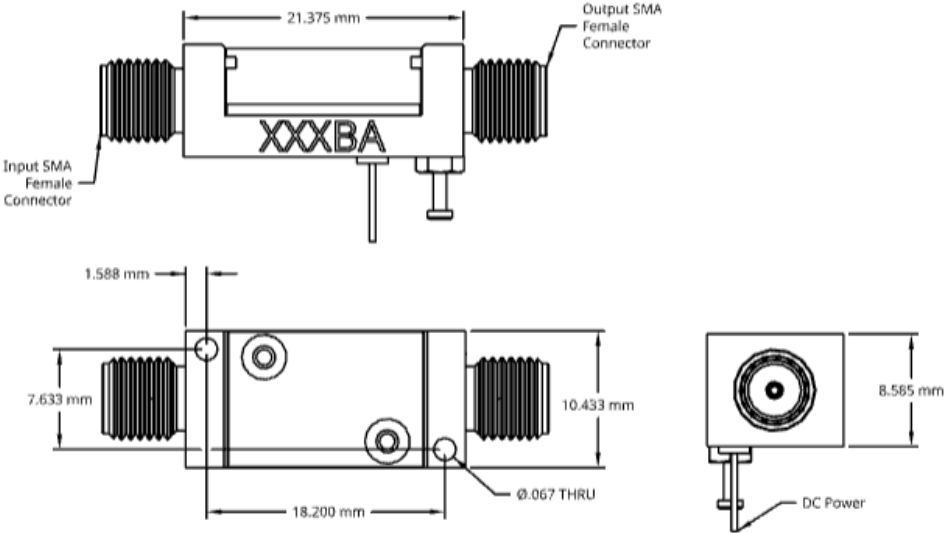

\*Dimensions are in mm

## Miniature Chassis with Bias Tees

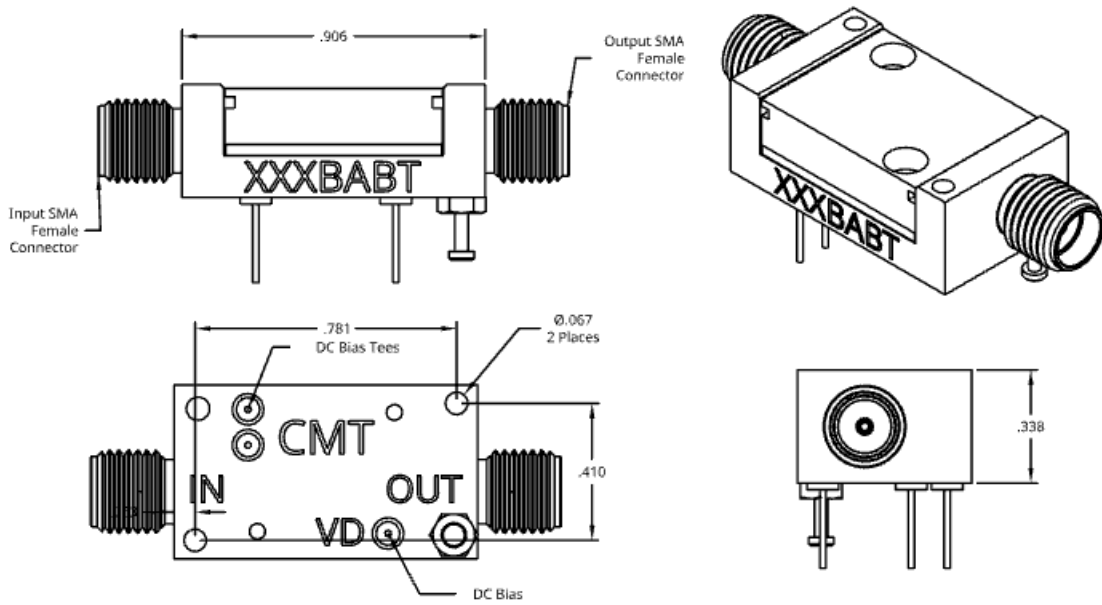

## Multichannel Quad Amp

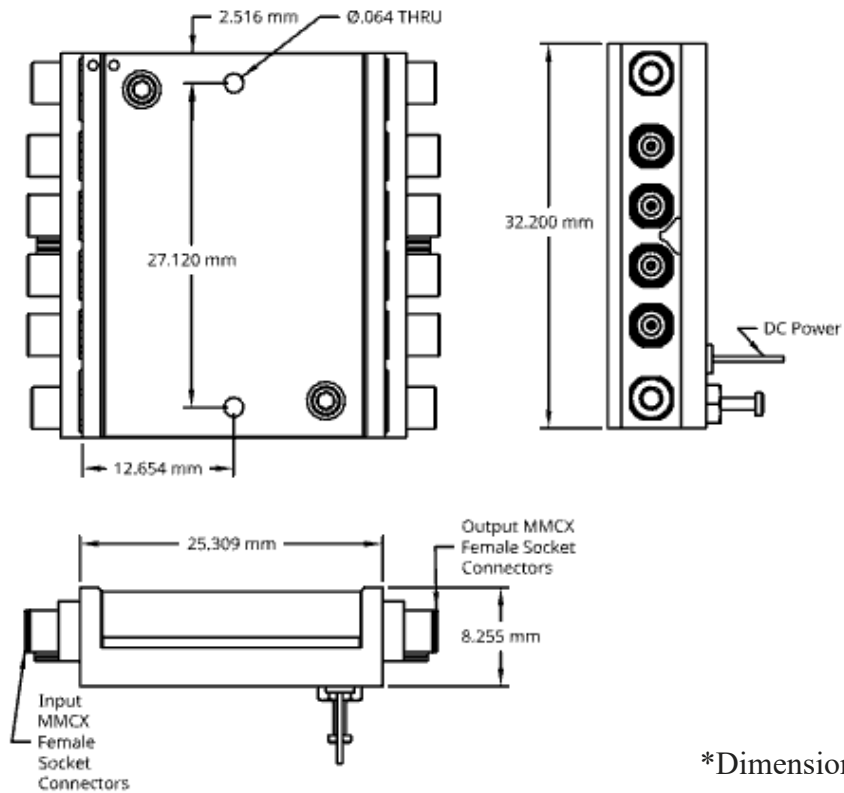

\*Dimensions are in mm

# CAD Housing Drawing – Shielded SMA Connectors

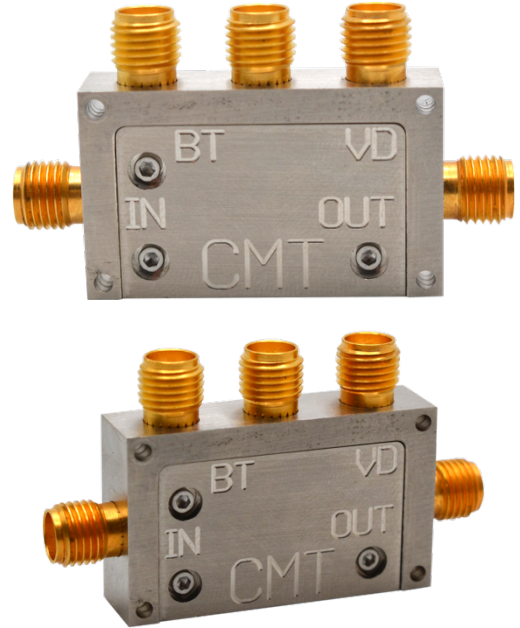
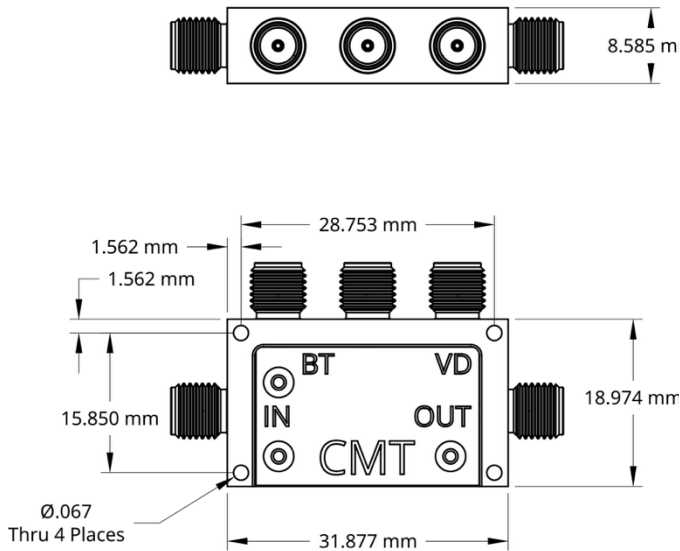

## Optional Input Bias Tee

As an option, the amplifier can be supplied with a DC bias tee for an external device connected to the amplifier input. The bias tee is formed by two (2) resistors connected to the input; as shown in Figure 1. One (1) resistor can be used as a source of current and the other senses the voltage across the external device. Voltages applied to the bias tee have a small effect on amplifier operation. At 12 K, 20 K $\Omega$  resistors increase noise by 0.5 K.

To order an amplifier with internal bias resistors, add the resistance to the part #. For instance, CITLF2-20K.

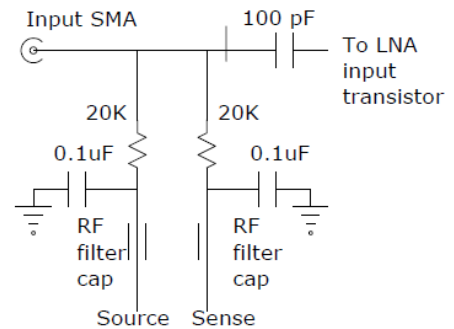
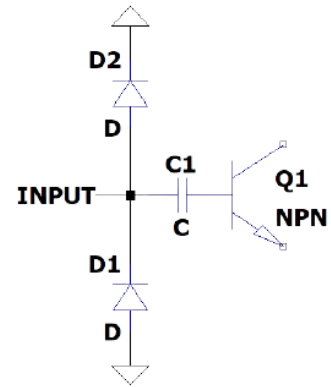

Figure 1. Bias Tee Schematic

# Optional Input Protection Diodes

As an option, the amplifier can be supplied with ESD protection & voltage spike protection at the RF input to the amplifier. There will be a slight degradation of the amplifier performance. Please note that the optional input protection diodes cannot be used if DC voltages are applied to the RF line using input bias tees.

To order an amplifier with internal bias resistors, add the resistance to the part #. For instance, CITLF2-PD.



**D1 & D2 = Input Protection Diodes**

Figure 2. Protection Diodes Schematic

## Product Care and Maintenance

- Use care to not bend (and break) the DC bias pin when tightening the output SMA connector.
- The amplifier should not be connected to the power supply when connecting the input connector.
- Set the power of Port 1 in your VNA to be less than -45 dB when testing the amplifier. Otherwise, the amplifier may saturate and the data obtained will be incorrect.
- Do not attempt to open the amplifier.
- Electrostatic discharge may damage the amplifier.

## Contact Information

### Sales & Quotes

[Sales@CosmicMicroTech.com](mailto:Sales@CosmicMicroTech.com)

### Non-Technical Questions

**Name** Ms. Denise L. Smith  
**Email Address** [Denise@CosmicMicroTech.com](mailto:Denise@CosmicMicroTech.com)  
**Phone Number** +1 (424) 456-7722  
**Address** 15711 Condon Avenue, Unit A3, Lawndale, CA 90260, USA

### Technical Questions

**Name** Mr. Stephen Smith  
**Email Address** [Steve@CosmicMicroTech.com](mailto:Steve@CosmicMicroTech.com)  
**Phone Number** +1 (424) 456-7744  
**Address** 15711 Condon Avenue, Unit A3, Lawndale, CA 90260, USA

*Specifications are subject to change without notice. Information supplied by CMT is accurate and reliable to the best of our knowledge.*