



QRFH-HA-6-FL Quad Ridged Flared Horns

SPECIFICATIONS

- Frequency Range: FL to 6*FL GHZ.
- Aperture Efficiency for Half-Angle, HA: >50%, typically >55%.
(Aperture efficiency is for a fix position of the feed relative to the reflector focal point, i.e., any degradation due to phase center variation with frequency is included in the specification.)
- Output Reference Impedance: 50 ohms.
- Return Loss: >10 dB, >15 dB over 90% of the band
- Maximum Diameter: 40cm/FL for HA=50
- Length: 34cm/FL for HA=50
- Approximate Weight: 0.7kg/(FL³) for HA=50



Description

QRFH-HA-6-FL feeds are Quad-Ridge Flared Horn antennas designed to efficiently illuminate microwave reflector antennas over a frequency range of FL to 6FL GHz where FL is to be specified for each feed and can range from 0.5 to 3 GHz. The feeds are dual-linear polarized designed for a given half-angle, HA, subtended by the reflector or sub-reflector facing the feed, specified for each feed. A typical feed that has been constructed and tested with a shaped Cassegrain reflector is the QRFH-50-6-2 shown above.

The feeds are constructed entirely of aluminum, except for the coaxial line center conductor and SMA connectors, which are gold-plated steel. The feed may be operated at any temperature in the 4K to 350K range with very little change in performance.

An important characteristic of all antennas is the scaling of performance with wavelength relative to dimensions. Thus, the measured return loss and patterns of the antenna with FL=2 GHz can be expected at frequency 2/X GHz for an antenna with all dimensions multiplied by X. The QRFH antenna can be scaled except for the SMA connector which has only minor effect on return loss for frequencies up to 18 GHz.

Measured Return Loss of QRFH-50-6-2

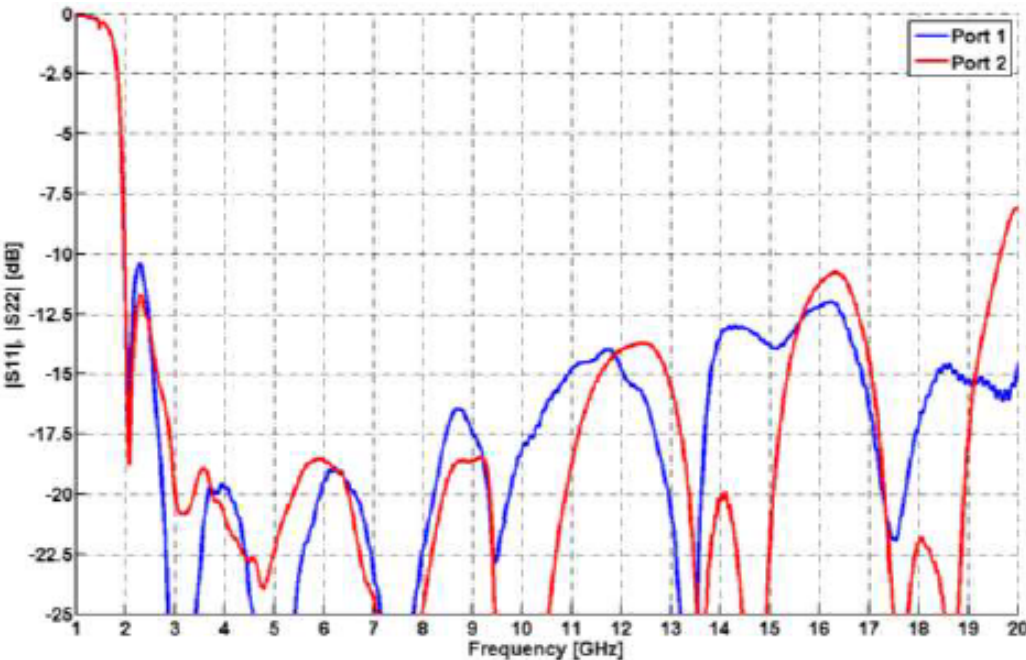

Measured Patterns of QRFH-50-6-2

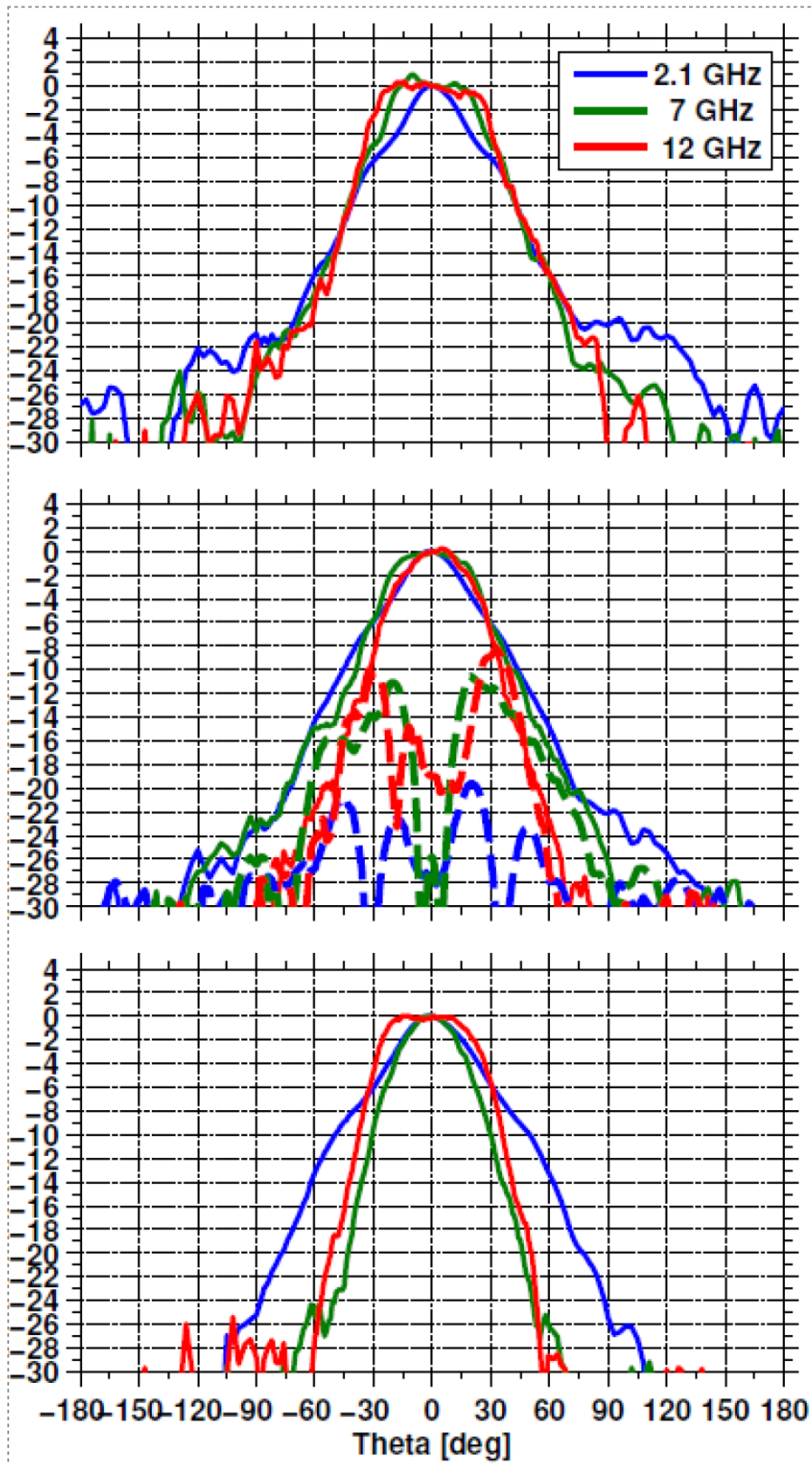

Measured patterns in E, H, and D (45°) planes, respectively, from top to bottom. Cross-pol in D-plane is plotted using dashed lines.

Outline Drawing and Mounting Plate Dimensions

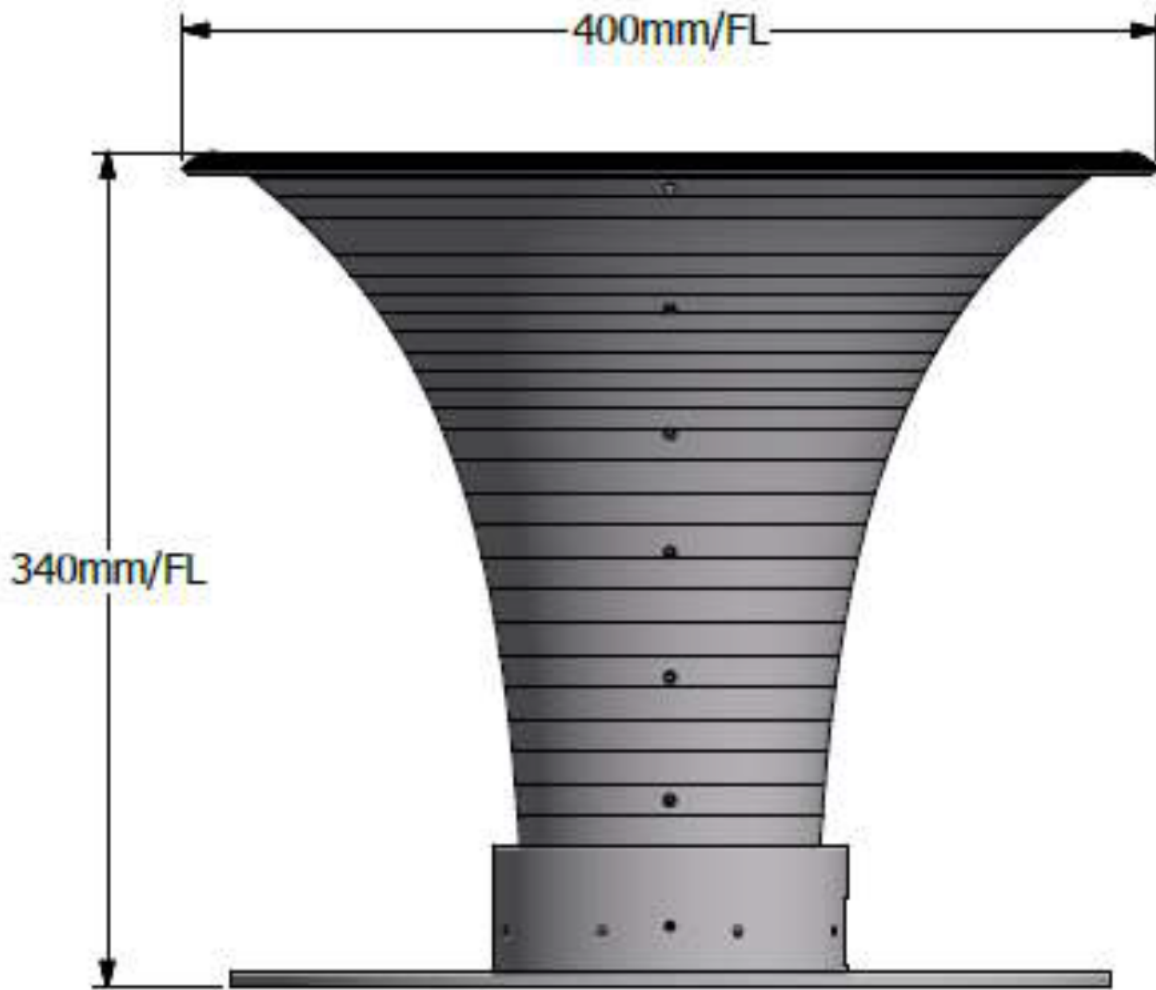

The back mounting plate has diameter 350mm/FL and thickness 4.76mm. A detailed drawing of the plate showing the back ring of the feed and connector locations will be provided with each feed.

Contact Information

Sales & Quotes

Name Ms. Denise L. Smith
Email Address Denise@CosmicMicroTech.com
Phone Number +1 (424) 456-7722
Address 15711 Condon Avenue, Unit A3, Lawndale, CA 90260, USA

Technical Questions

Name Mr. Stephen Smith
Email Address Steve@CosmicMicroTech.com
Phone Number +1 (424) 456-7744
Address 15711 Condon Avenue, Unit A3, Lawndale, CA 90260, USA