



NEW! Miniaturized NEW! Multi-Channel

CMT-BA1

Cryogenic SiGe Low Noise Amplifier

KEY FEATURES

- Applications include Radio Astronomy and low temperature physics.
- Single supply operation
- Female SMA connectors standard
- SMPM connectors available
- Optional input DC bias tees
- Standard size 27.1 x 15.9 x 8.7 mm
- Miniature size 21.3 x 10.4 x 8.5 mm
- Quad Amplifier size 25.3 x 32.2 x 8.3 mm

PERFORMANCE FEATURES

- RF frequency
 - 0.005 to 1.5 GHz
- Gain
 - 32 dB \pm 2 dB
- Noise temperature
 - < 2.0 K @ 5-500 MHz
 - < 4.7 K up to 1.5GHz
- Optimum DC Power
 - Vd = 2.0 V
 - Id = 13 mA

APPLICATIONS

- ✓ Radio astronomy arrays
- ✓ Superconducting Nano Wire Single Photon Detectors
- ✓ Low Temperature Physics Experiments

Description

The CMT-BA1 is a cryogenic SiGe low noise amplifier ideal for Radio Astronomy and Low Frequency Physics applications. The CMT-BA1 is an upgrade from our LF1 amplifier. This amplifier covers the frequency range of 0.005 to 1.5 GHz. The typical noise temperature is less than 2.0 K from 5 to 500 MHz and less than 4.7 K up to 1.5 GHz. The gain of the amplifier is typically 32 dB with a gain flatness of \pm 1 dB.

DC power is supplied from a single DC power source. Optimum performance is obtained with a supply voltage of 2.0 V. The supply current is 13 mA at this voltage. The supply voltage can be reduced to 1.5 V @ 6.5 mA for low power applications.

The standard chassis is 27.1 x 15.9 x 8.7 mm excluding connectors. The amplifier is also available in our NEW miniature version which is 21.3 x 10.4 x 8.5 mm without bias tees and 23.0 x 13.2 x 8.5 mm with bias tees.

CMT is also producing a Quad amp version which contains four independent amplifiers in a single package with the size of 25.3 x 32.2 x 8.3 mm and a dual amplifier configuration, and a chassis that incorporated shielded SMA connectors for ALL DC connections, amplifier supply and input DC Bias tees.

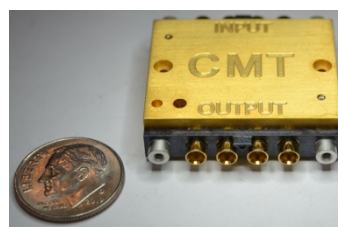

Multichannel Quad Amp

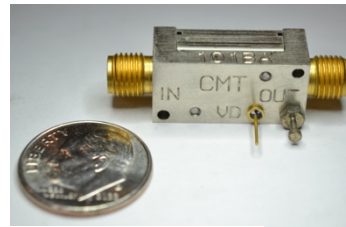

Miniature BA Chassis

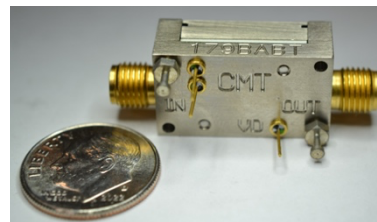

Miniature BAPT with Bias Tees

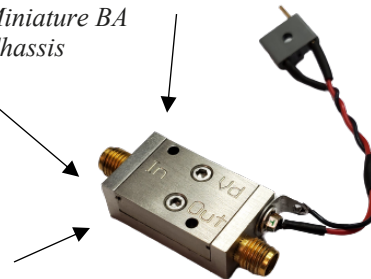

DC CONNECTIONS FOR HIGH NOISE ENVIRONMENTS

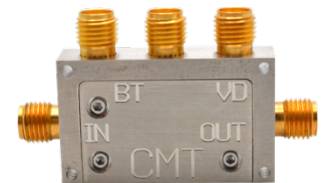

New shielded SMA connectors

Electrical Specifications @ 12 K

Description	Typical	Minimum	Maximum
RF Frequency		0.005 GHz	1.5 GHz
Gain		32 dB \pm 2 dB	
Noise Temperature	< 4.3K	2.0 K	4.7 K
IRL (-20log S ₁₁)	-15 dB	< -10 dB	
ORL (-20log S ₂₂)	- 10 dB	< -10 dB	
DC Voltage	2.0 V	1.5 V	3 V
DC Current	13.1 mA	6.5 mA	25 mA

Electrical Specifications @ 300 K

Description	Typical	Minimum	Maximum
RF Frequency		0.001 GHz	1.5 GHz
Gain @ 2.5V	27 dB	27 dB \pm 2 dB	
Noise Temperature @ 2.5V	< 60K	35K	55K
IRL (-20log S ₁₁)		< -10 dB	
ORL (-20log S ₂₂)		< -15 dB	
DC Voltage	2.5 V	1.1 V	5 V
DC Current	10.6 mA	2.2 mA	2.6 mA

Typical Test Results – Optimum DC Bias @ 13 K

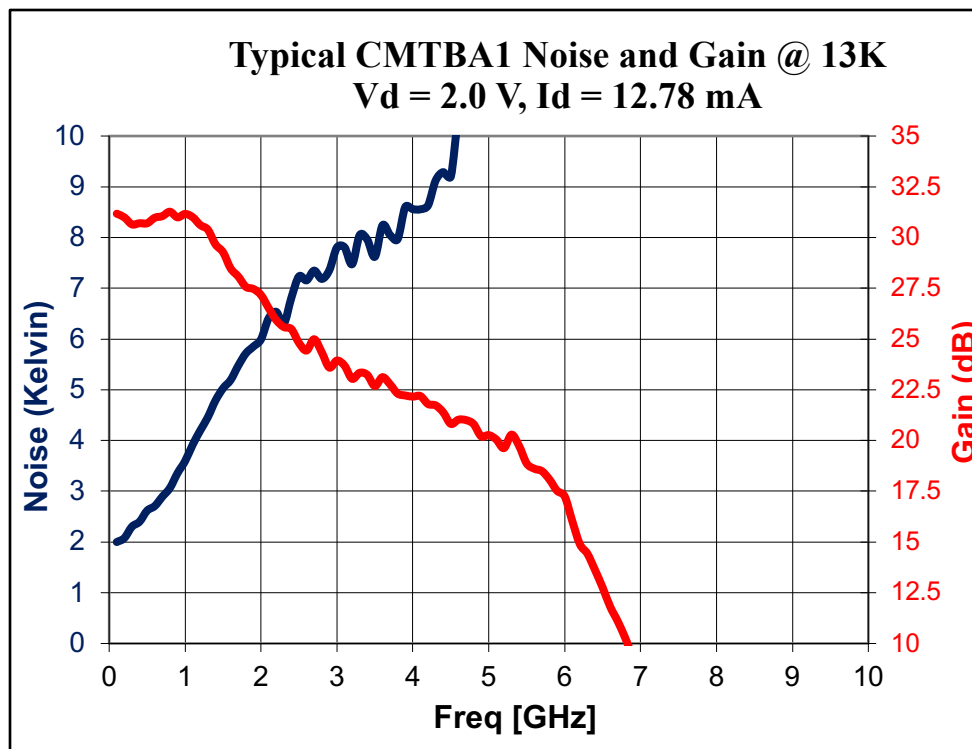
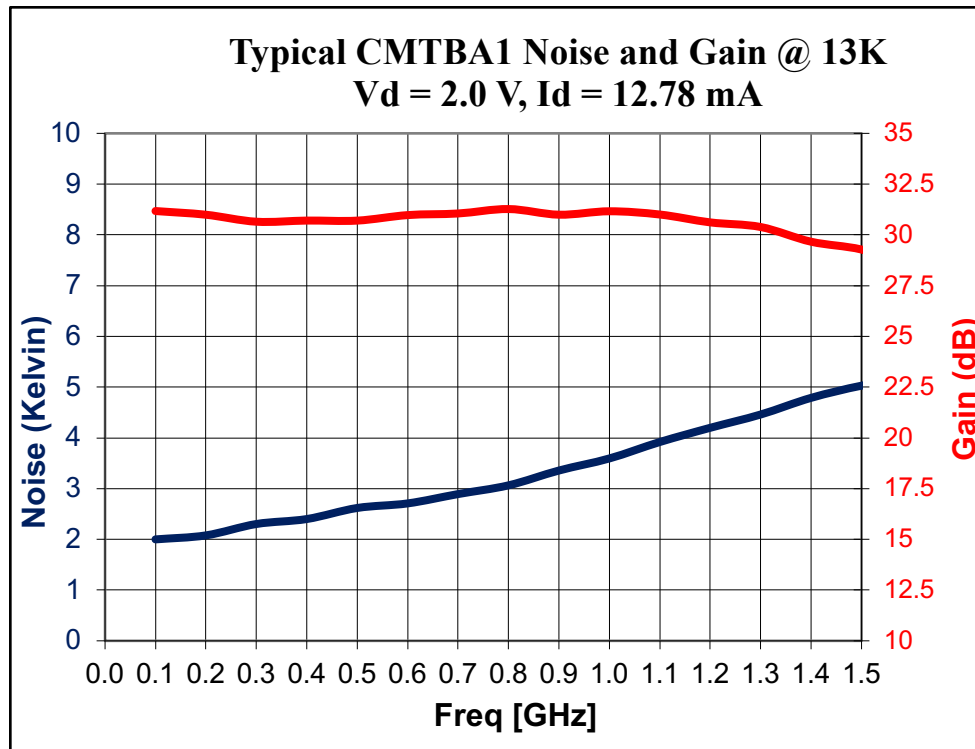

Typical CMT-BA1 Very Low Frequency Noise

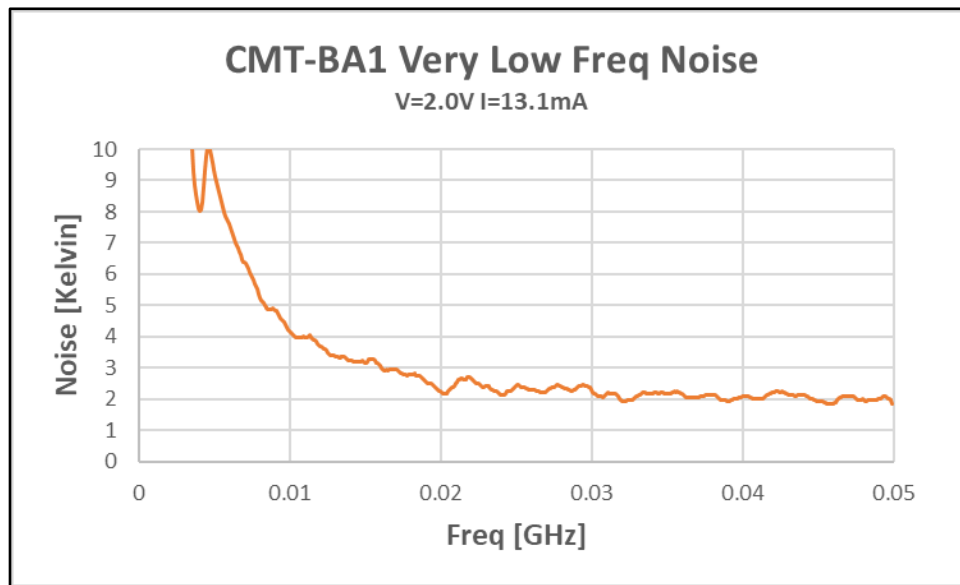

Typical CMT-BA1 Return Loss @ 13 K

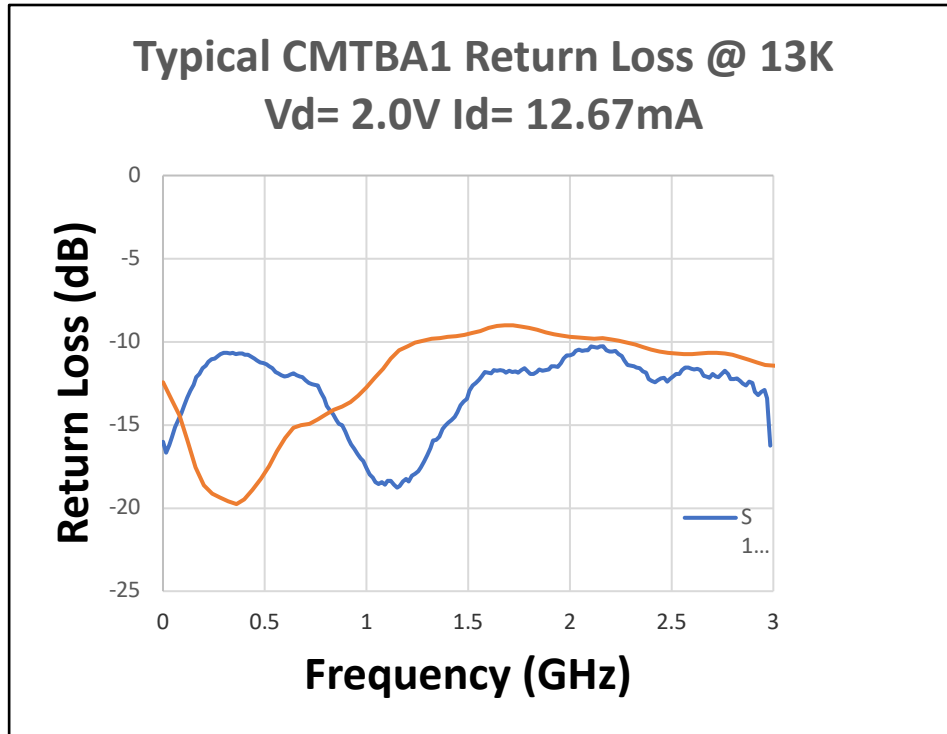

Typical CMT-BA1 Return Loss @ 12K

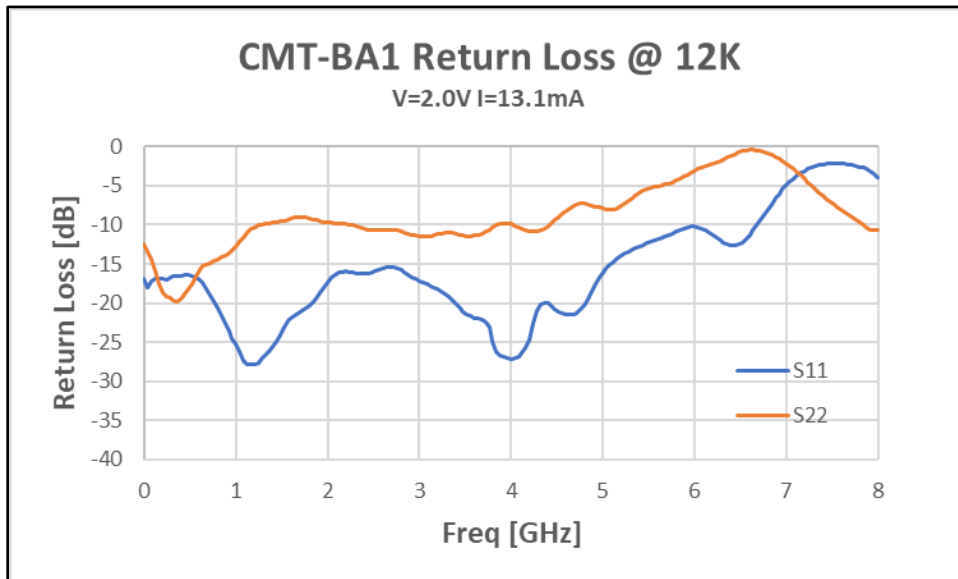

Typical CMT-BA1 Input Return Loss

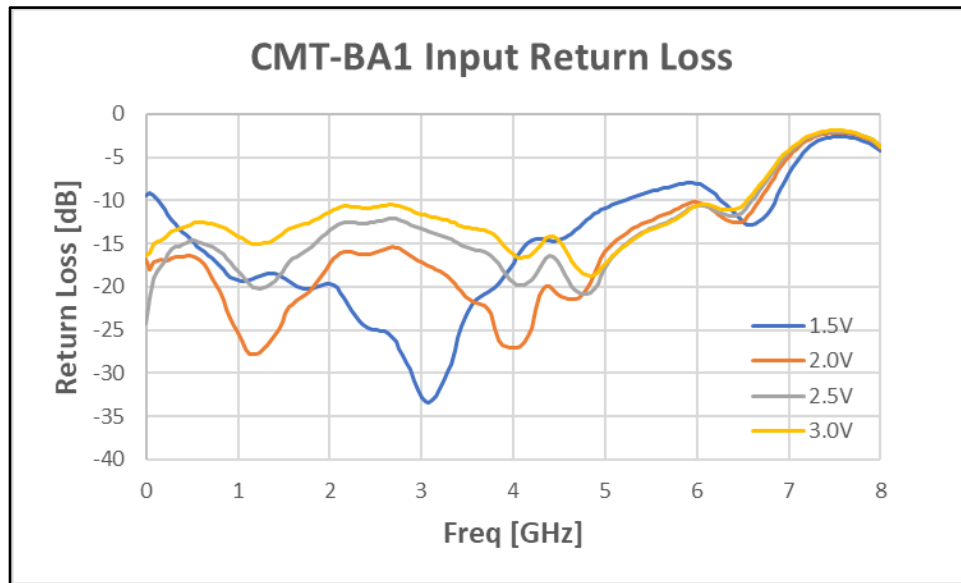

Typical CMT-BA1 Output Return Loss

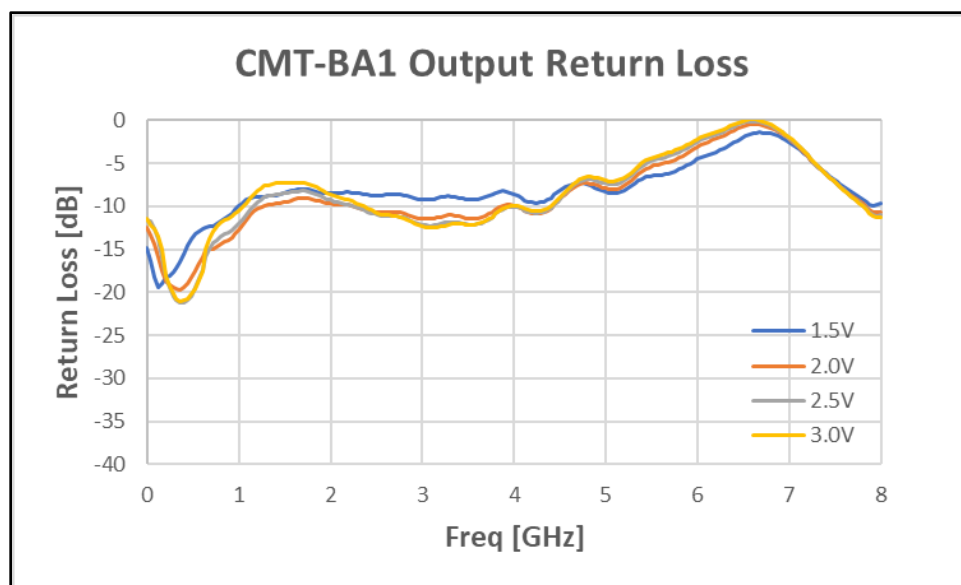

Typical CMT-BA1 Gain

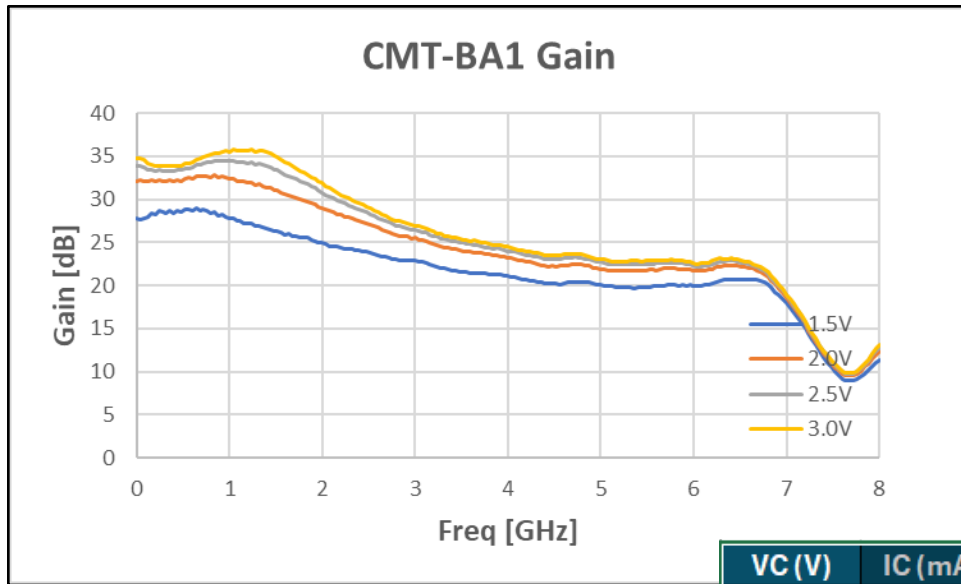

VC (V)	IC (mA)	PD (mW)
1.50	6.53	9.80
2.00	13.00	26.00
2.50	19.49	48.73
3.00	26.00	78.00

Typical Test Results – Optimum DC Bias @ 300 K

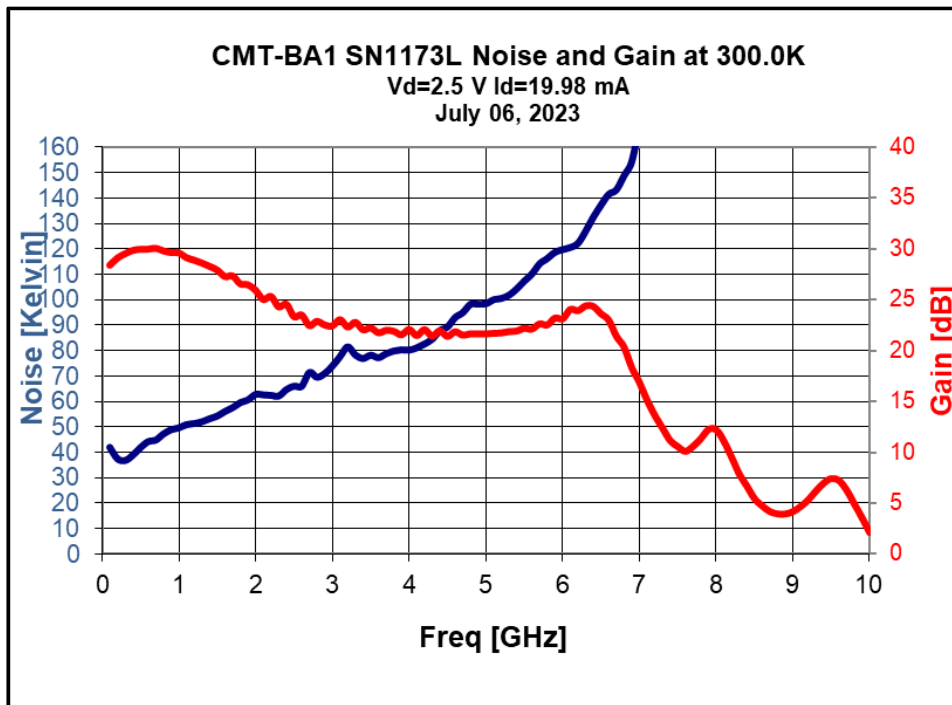

Typical CMT-BA1 P1dB Compression @ 4 K

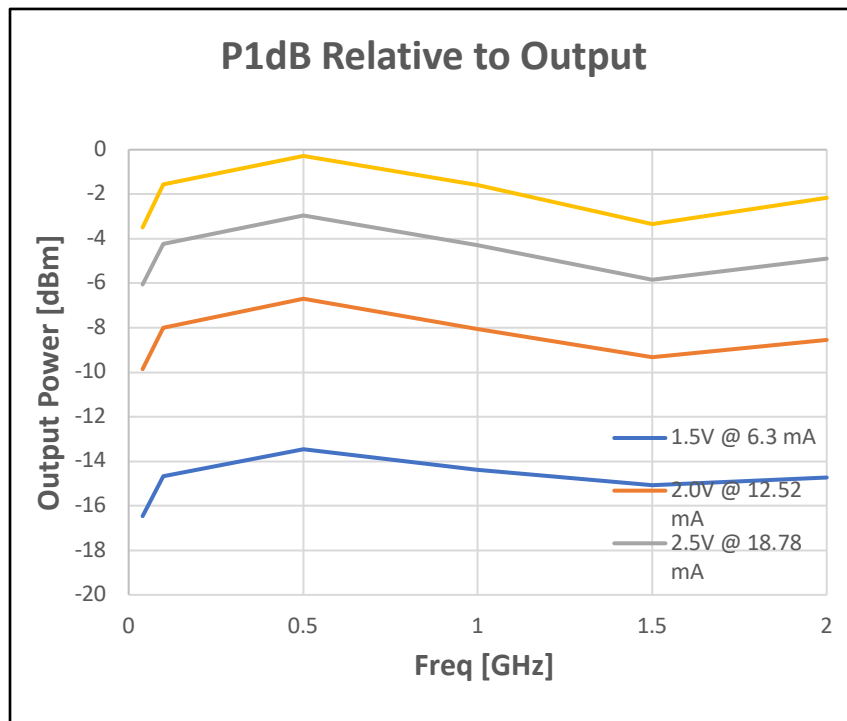
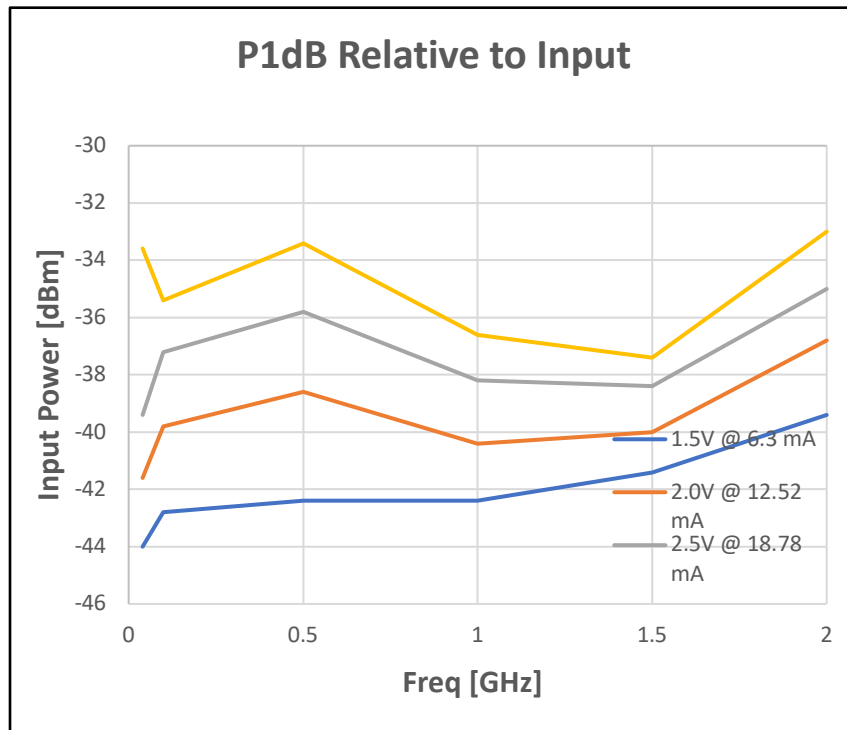

CAD Housing Drawing

Regular Chassis

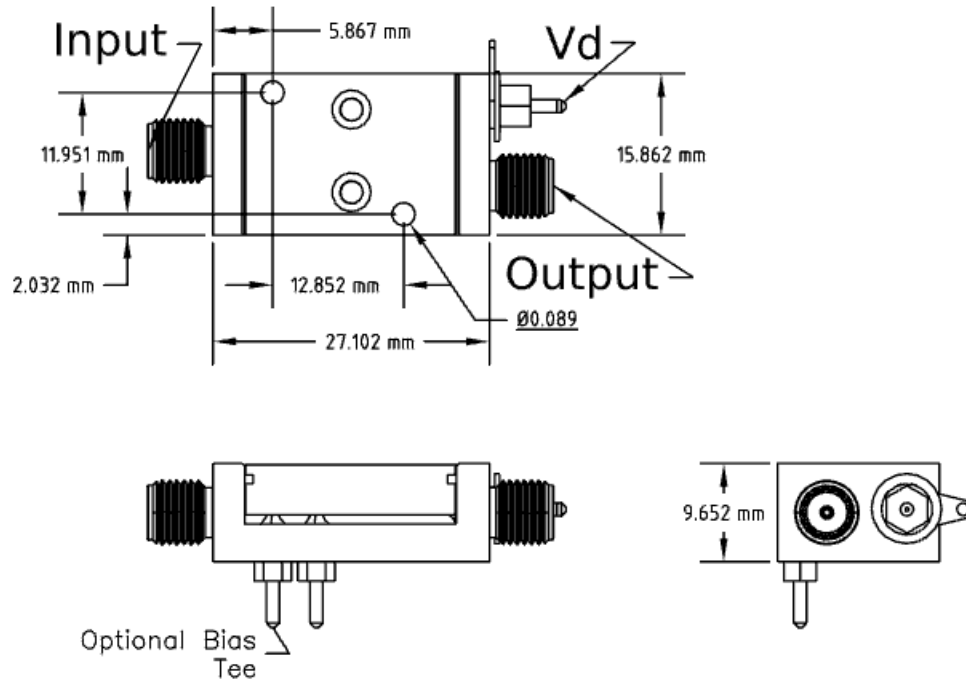

Miniature Chassis

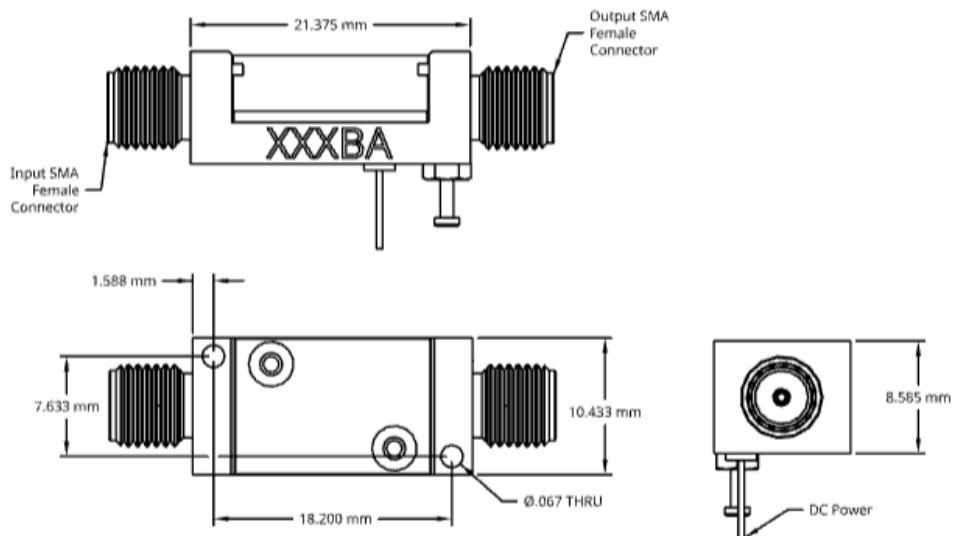

*Dimensions are in mm

Miniature Chassis with Bias Tees

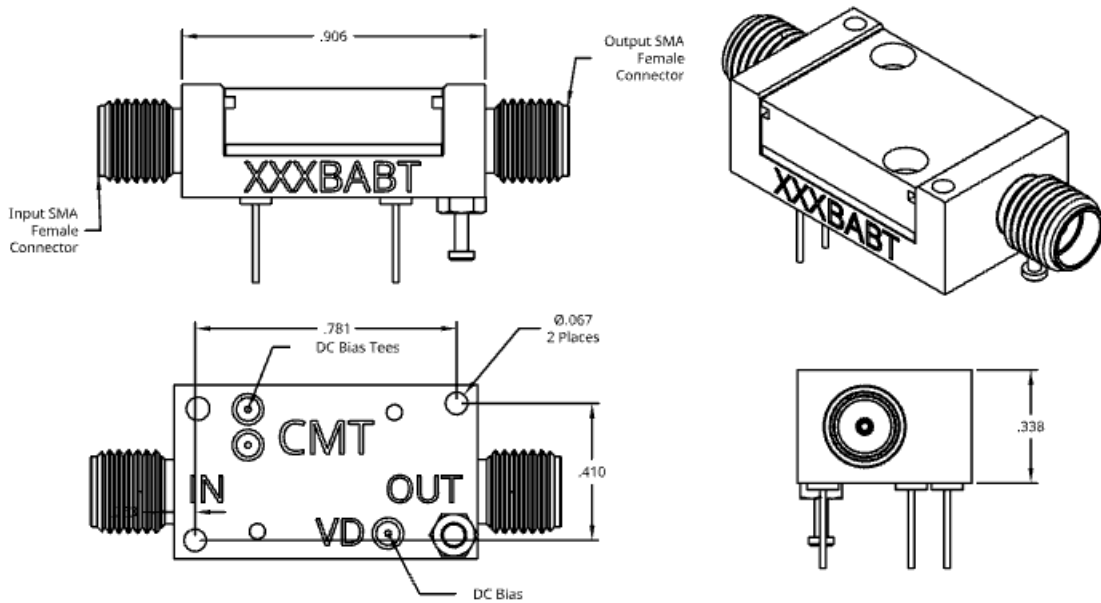

Multichannel Quad Amp

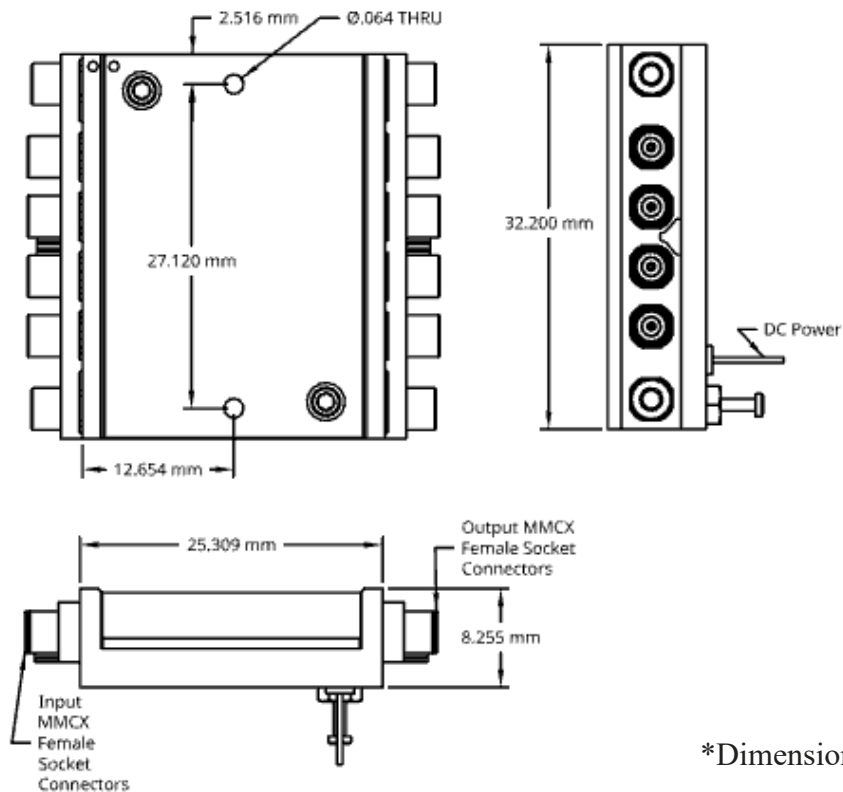

*Dimensions are in mm

CAD Housing Drawing – Shielded SMA Connectors

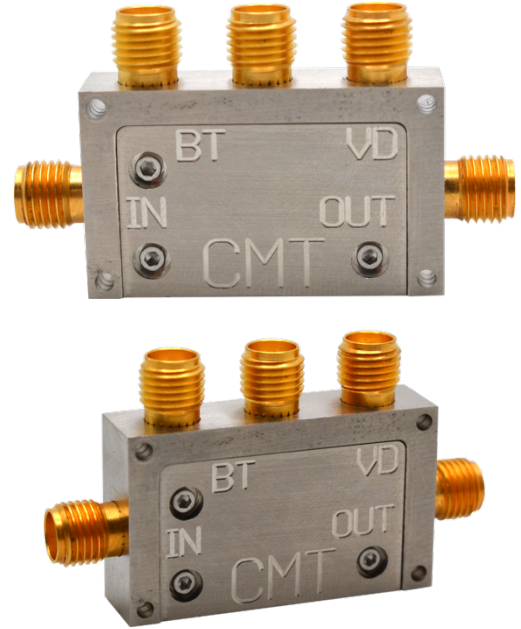
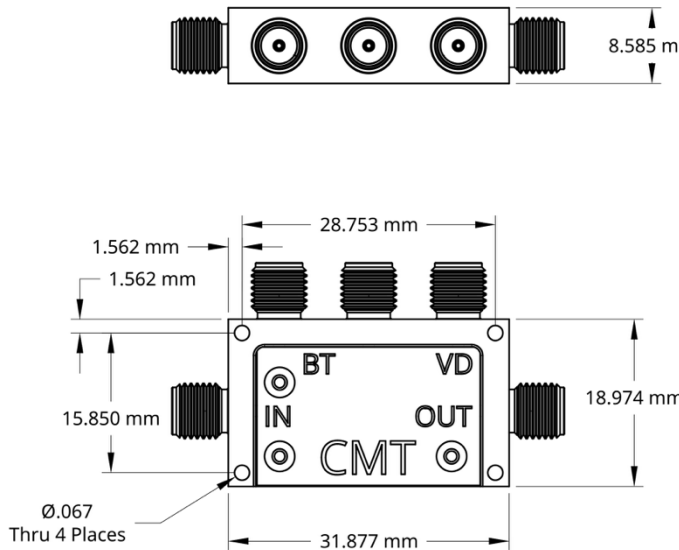

Optional Input Bias Tee

As an option, the amplifier can be supplied with a DC bias tee for an external device connected to the amplifier input. The bias tee is formed by two (2) resistors connected to the input; as shown in Figure 1. One (1) resistor can be used as a source of current and the other senses the voltage across the external device. Voltages applied to the bias tee have a small effect on amplifier operation. At 12 K, 20 K Ω resistors increase noise by 0.5 K.

To order an amplifier with internal bias resistors, add the resistance to the part #. For instance, CMT-BA1-20K.

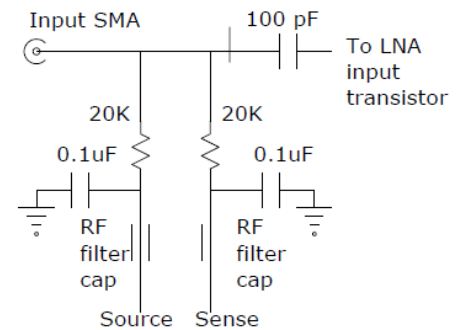
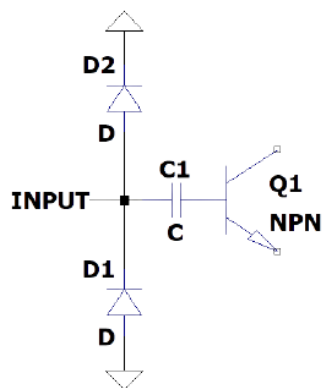

Figure 1. Bias Tee Schematic

Optional Input Protection Diodes

As an option, the amplifier can be supplied with ESD protection & voltage spike protection at the RF input to the amplifier. There will be a slight degradation of the amplifier performance. Please note that the optional input protection diodes cannot be used if DC voltages are applied to the RF line using input bias tees.

To order an amplifier with internal bias resistors, add the resistance to the part #. For instance, CMT-BA1-12D-PD.



D1 & D2 = Input Protection Diodes

Figure 2. Protection Diodes Schematic

Product Care and Maintenance

- Use care to not bend (and break) the DC bias pin when tightening the output SMA connector.
- The amplifier should not be connected to the power supply when connecting the input connector.
- Set the power of Port 1 in your VNA to be less than -45 dB when testing the amplifier. Otherwise, the amplifier may saturate, and the data obtained will be incorrect.
- Do not attempt to open the amplifier.
- Electrostatic discharge may damage the amplifier.

Contact Information

Sales & Quotes

Sales@CosmicMicroTech.com

Non-Technical Questions

Name

Ms. Denise L. Smith

Email Address

Denise@CosmicMicroTech.com

Phone Number

+1 (424) 456-7722

Address

15711 Condon Avenue, Unit A3, Lawndale, CA 90260, USA

Technical Questions

Name

Mr. Stephen Smith

Email Address

Steve@CosmicMicroTech.com

Phone Number

+1 (424) 456-7744

Address

15711 Condon Avenue, Unit A3, Lawndale, CA 90260, USA

Specifications are subject to change without notice. Information supplied by CMT is accurate and reliable to the best of our knowledge.